

THE ARUP JOURNAL



MARCH 1966



THE ARUP JOURNAL

Published March 1966 by
Ove Arup & Partners, 13 Fitzroy Street, London, W 1.

Editor: Rosemary Devine
Art Editor: Desmond Wyeth

Contents

The cover, front and back, shows the obverse and reverse of the RIBA Gold Medal (photos: Colin Westwood).

- 2 OBVERSE AND REVERSE
Peter Dunican
- 3 SYNTHESIS OF
LOAD-BEARING STRUCTURES
Povl Ahm
- 8 BOOTHAM SCHOOL ASSEMBLY HALL
Edmund Happold and Trevor Dannatt
- 12 RECENT ADDITIONS TO THE LIBRARY
- 13 TECHNICAL NOTES ISSUED BY
OVE ARUP & PARTNERS

Obverse and reverse

Peter Dunican

When Ove first told me that he was to be the 1966 RIBA Royal Gold Medallist, my real pleasure sprang from the thought that at last he would be given what is probably the most significant honour which the architectural profession in this country can bestow upon an engineer. In 1960 the medal was awarded to an engineer for the first time - Nervi. It was then quite obvious that the Council of the RIBA was taking a most enlightened view of its terms of reference which state that the Royal Gold Medal is to be conferred 'on some distinguished Architect, or man of Science or Letters, who has designed or executed a building of high merit, or produced a work tending to promote or facilitate the knowledge of Architecture or the various branches of science connected therewith or whose life work has promoted or facilitated the knowledge of Architecture or the various branches of science connected therewith'.

It was evident that Ove would eventually be asked to join the ranks of such Olympians as le Corbusier, Gropius, Aalto and Mies van der Røhe. I say 'eventually' with some conviction because the way in which the Gold Medallist is selected is essentially democratic. The Council of the RIBA annually appoints an Awards Committee which is responsible for making a specific recommendation to the Council from the usually long list of nominations which can be made by any of the seventy-odd members of the Council. If the Council

accepts the recommendation, it then seeks the Queen's approval. There is no doubt that Ove was a unanimous choice - and quite right too. His work during the last two decades alone justifies this. Some people will think that I am prejudiced. So I am but I can be objective. After twenty odd years with Ove I have learnt something. In fact, I should have learnt a lot. If I haven't, it is my fault. Ove taught me many lessons, all in the same enlightening, generous, unique and inspiring way. I must say I didn't always understand him. Neither did I always agree with him. But then he wasn't always right. He never claimed to be, although I must say that sometimes the inference was pretty plain. I remember one particularly intense dispute . . . no, perhaps I shouldn't rake up old scores. After all, I know that I was right. I just wasn't able to convince him. Nevertheless, as usual, he let me do what I wanted - this is another of his great qualities - letting people decide for themselves.

During the last year particularly, many eulogies of Ove have been published and he is probably getting a bit fed up with it all. But this is only one of the penalties of fame. Still, he endures it with some relish as his recent television performance clearly showed. How many engineers could reflect so succinctly on the Newtonian aspects of mountain climbing, or commend so convincingly such an acceptable concept of inefficiency? Of course, not everyone approved of the BBC's portrait. Not surprisingly, Ove was highly critical of his own performance. He suggested to me, perhaps tentatively, that he was a bad speaker. For once I agreed but not for any reason of contrariness nor for the too often remarked fact that he rarely finishes a sentence. But because, in a way, he is. He has too many ideas. His ideas flow quicker than words can be formed. He really indulges in a sort of semi-telepathic communication. Of course, it is difficult to paint the portrait of such a character in fifty minutes. In fact, it is not easy to paint a completely balanced picture - even when time is unlimited. Perhaps Ove should take up painting. He seems to do many things mostly well. But would he accept Cromwell's direction to his portrait painter to 'remark all these roughnesses, pimples, warts and everything as you see me, otherwise I will never pay a farthing . . .'? I am sure Ove would concern himself fundamentally with the essential truth, as he saw it and as abstract as this might be.

The other day Ove was interviewed - if that is the right word - by one more journalist. Subsequently the poor man asked me to help him. He said that in the two hours' discussion he had tried to find examples of work for which Ove was personally responsible. The only one to emerge was the Durham footbridge! Surely, Ove had done more than one small footbridge? Well, of course he has, but this sort of question cannot be answered simply. And daft questions provoke daft answers. It is rather like expecting the captain of the football team to score all the goals. The great captains create the opportunities. It is the teams which score.

Ove is a great individualist and perhaps temperamentally, if not ideologically, doesn't seem best suited to playing in with the team. But of course he does. He has always recognized the need for team working - for the intimate collaboration of equals in this most complex business of designing buildings. Through his achievements we, the structural engineers that is, are now regarded as worthy and worthwhile collaborators - not just some sort of sub-contracting plumbers called in at the last moment to make whatever it is stand up.

Ove has established for us a place in our society. He has done this through a variety of means - but primarily through his firm. Under his guidance we have learnt that although structure is important it is the building which matters most. He has shown us what can be achieved through willingness, technical excellence and an awareness of the social significance of our work. For this alone he deserves the Gold Medal.

If any further tribute is necessary - and Ove would be the first to say that it wasn't - you must look at the work which has been created with the help of our firm and you must look at our firm, which Ove Arup created. This should be enough for any man.

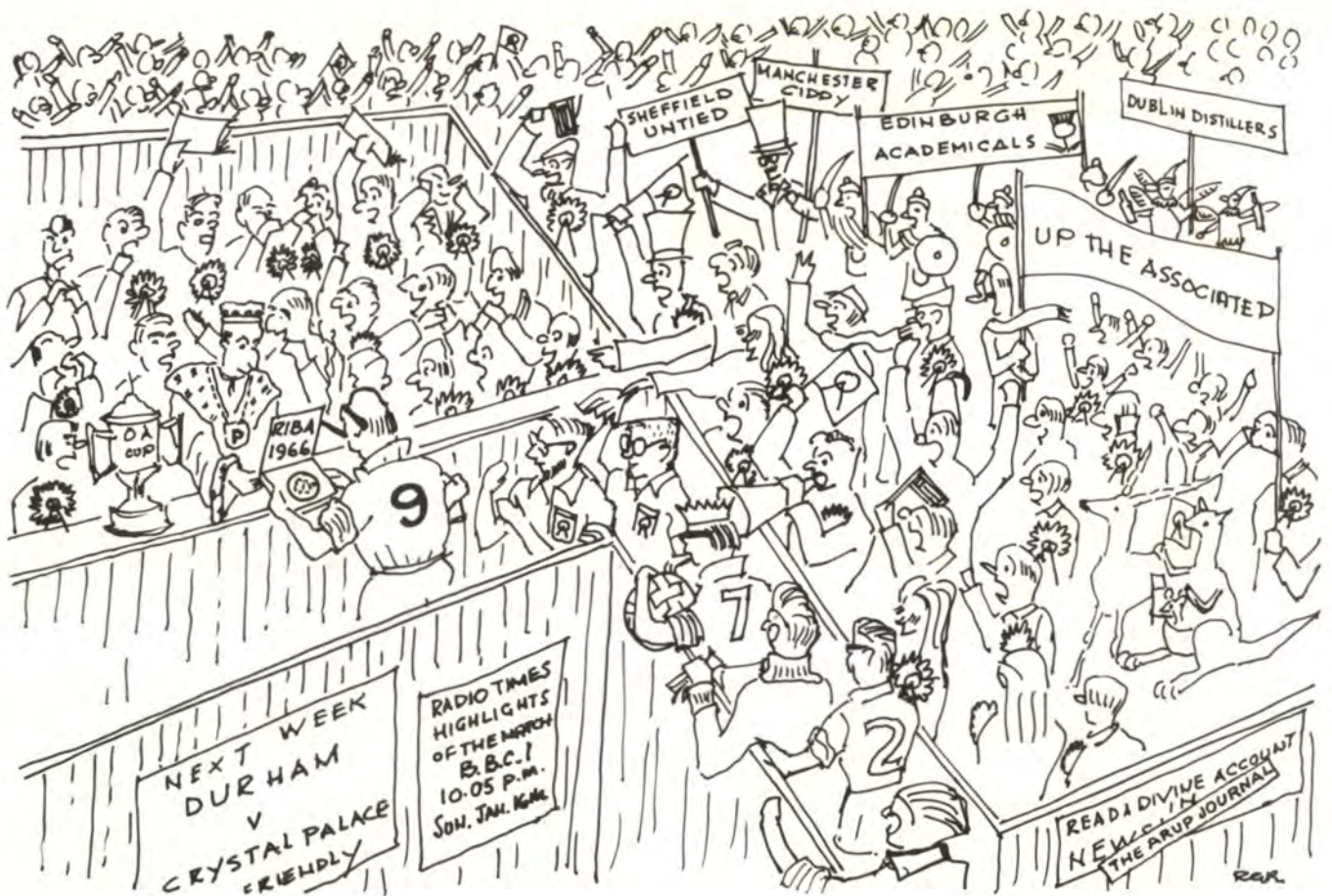

Synthesis of load-bearing structures

Povl Ahm

Articles on load-bearing structures generally deal with analysis of the structure; therefore perhaps it would be interesting for a change to consider the synthesis - the process of creating the structure. Analysis in this context means taking the structure to pieces and considering each member individually and collectively, in order to decide whether it is satisfactory for its purpose. Synthesis ought to be analysis in reverse. The difficulty lies in deciding what it is the reverse of - therefore, in reality, synthesis must come before analysis.

In the end some form of analysis is, of course, necessary to make sure of the adequacy of the structure - either by comparison with existing structures or members that are known to be all right, or by making a true model of the structure and comparing the calculated results with known criteria such as strength, deformation, failure, etc.

But no structure will be created by calculating it or by analyzing it. Analysis is like a vocabulary. It enables you to speak and write, and the larger it is the better you do it. It is necessary to have a vocabulary, but it is not enough. A vocabulary can be acquired by learning dictionaries by heart, as can analysis by reading text books, but one does not get far without knowing why and how the acquired knowledge should be used.

Engineering is not only a science, it is also an art. In fact, all creative science is also art. Einstein's theory of relativity was not conceived by carefully laying stone upon stone, but by a sudden insight revealing a completely new relationship out of knowledge which already existed.

* This is a translation of the article that appeared in Danish in *Ingeniøren*, 74, 10 (325-334) 1965.

Engineering science - or engineering art - obviously developed a long time before one was able to create mathematical models of structures through definite assumptions and through these models find criteria for their safety. From the beginning of time the possibility of 'spanning' has engaged man's imagination and efforts. Firstly, observation of nature's 'constructions' - rocks, caves, trees, etc., then imitations of these and later, more advanced structures, developed through conclusions drawn from the observations. Man's first buildings were individual houses or huts of clay or wood. Real structures do not appear until common efforts develop larger works, such as temples, monumental tombs, etc. The Egyptians used beams, hewn out of rocks, to span between columns, creating enclosures of considerable size. The Greeks also used the beam and later the arch, built of small blocks kept in position just by pressing one against another. During Roman times and through the Middle Ages the vault was developed. The Pantheon can be called the first attempt at shell construction, though very solid and heavy. Much later Michelangelo built the dome over St. Peter's and the Mohammedans, domes of fantastic shapes, generally in stone or brick.

All these structures were created without real calculations as we know them now. They appeared as the result of observation and experience and some of them collapsed. The same form of construction was used over and over again and a very large amount of experience was gained. Architecture was developed by combining the same forms in various ways. The architect and the engineer were one and the same person. No calculations were made, but in spite of this - or perhaps because of this - works of great daring and beauty were created.

The materials - with the exception of timber - could take compression only or small tensile forces combined with compression.

The notion of internal forces or stresses and their equilibrium with external forces was unknown before the 18th century. Galileo was the first to understand the problem in principle but he assumed that the whole cross-section of a beam had tensile stress when bending. Nevertheless, the

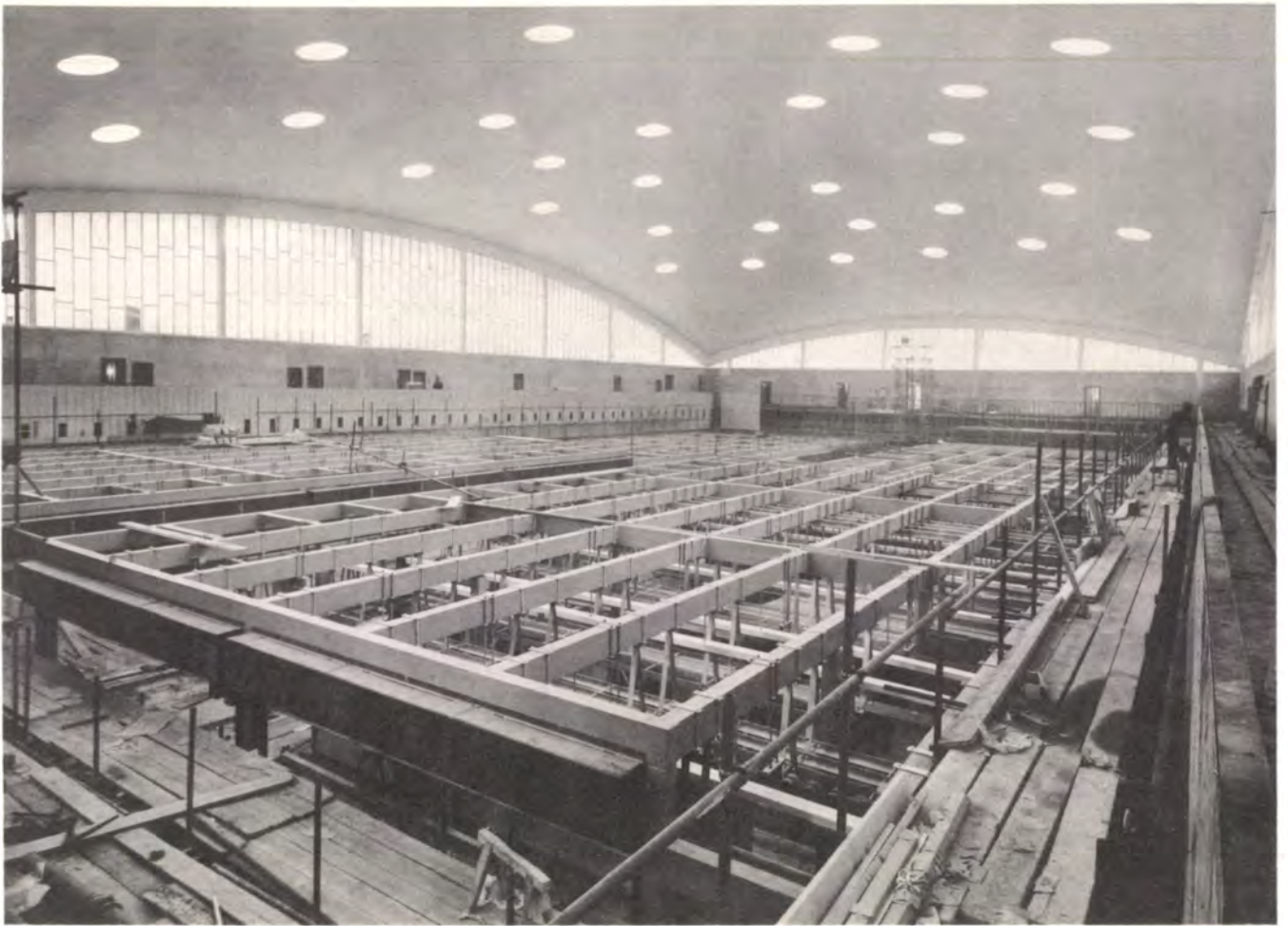

Above: Smithfield Market interior. Below: An exterior view. The shell is an elliptical paraboloid 230ft x 130ft.



old masters understood what made structures work, and they achieved clear and clean structures which are nowadays only too rare. The same can be said about engineering construction in the 19th century, although they then had wrought iron, which could take bending as well as tension. Two fine examples from this period are the Forth Bridge and Brunel's Clifton suspension bridge.

FUNCTION AND DESIGN

Today the picture is quite different. We have materials that will do nearly everything and building methods that perhaps leave little to be desired. But let us first consider the factors that play a part in the design of a structure. Why is the structure wanted and what purpose should it serve? Also, what is its function apart from protection against the weather and spanning from A to B, its use, the movement of people, vehicles and other traffic inside the structure or over it? How should it be divided up? How should the necessary installations be carried to the places where they are wanted.

It is a complicated job to study the function of a structure. It requires collaboration between several experts, each with his special knowledge and interests. This collaboration is often neglected to a greater or lesser degree, and the results show it only too clearly.

Before commencing the actual design of a structure, its purpose and function must be studied from all aspects and the job as a whole must be understood before calculations and details are begun. Conditions on site, loading, possibilities for supports, and foundations must be examined, also maintenance, attack from chemical and physical forces, requirements for special materials, etc.

Nearly all structures have certain financial aspects or limitations. Few are above economic considerations. Generally the cheapest solution must be chosen. It is not, however, always easy to decide which solution is the most economic. It depends on the required safety and life of the structure, its appearance, use, etc. Apart from the actual cost of construction, other economic factors must be examined. The economy must always be considered on a broad basis. Sometimes it can be assessed in £.s.d., but not always, particularly for large undertakings or when new developments inside the building industry take place. One must consider the supply of materials, availability of labour, import, export, etc. New developments in building could alter the basis and upset the calculations.

COST

Of course, the cost deserves special attention, but it is not always the deciding factor and should certainly never be the only deciding factor. The most important thing is that one gets value for money, but it is not always easy to get the client to accept this point of view. The appearance of all structures is of fundamental importance to people in and around them. It is often said that whereas one building is of such importance that a certain amount must be spent on its appearance, in the case of another building its use is the only thing which matters and it should therefore be as cheap as possible, irrespective of its appearance. Of course it is true that appearance generally costs money and should therefore in each case be assessed in value, but this is only partly correct. Much can be achieved without extra cost, particularly with the materials available today. Even the cheapest building can be pleasant in appearance if the materials are studied and the details, as well as the main concept, carefully considered. Low cost is often made an excuse for poor appearance which is really due to lack of care in the design.

The so-called prestige buildings are as difficult as simple buildings - or perhaps more so. Architects and engineers may easily lose control and discipline when, with ample funds available, they try to produce a building which would be an advertisement for the client.

Aesthetic considerations are abstract in character, although it is debatable how abstract they really are. It is therefore difficult to decide to what extent the demand nowadays that a structure must show what goes on inside it is

solely a matter of emotion, and to what extent it is intellectual in nature.

The materials must be studied more closely. They should be selected only after examination of many points - suitability, availability, cost, durability, method of construction, appearance etc., also their strength, elasticity, plasticity, and mode of failure, and further, their ability to resist temperature, moisture, fire, chemicals, etc. In order to produce a satisfactory structure it is necessary to have an intimate knowledge of the possibilities offered by the materials and the limitations they impose.

The method of construction must also be considered. It may decide the layout for the structure and the procedure and programme for the work, or, vice versa, a desired programme may require a definite method of construction. The engineer must realise this at an early stage of the design.

THE STRUCTURE

It will be noticed that all the factors mentioned influence one another in numerous ways. Out of this myriad of considerations, investigations, assumptions and comparisons the structure must emerge as a solution which, without necessarily fulfilling every single requirement to perfection, will satisfy as many demands as possible, with the simplicity and clarity which are the signs of genius. It is therefore no mean achievement to create a satisfactory structure and it is rarely accomplished.

The process which takes place when one conceives or creates a structure is art. It springs from personal experience and from intuition but is rarely or never the result of purely logical thinking. However, certain considerations can lead to thoughts and ideas which can feed and guide the imagination. These considerations may suitably be called the philosophy of structures.

When attempting to create a structure, it is necessary firstly to go through all solutions that are statically possible. These are decided by existing conditions - foundations, possible settlements, etc. - the size and nature of the loading, the function and importance of the structure, etc. They may be simple, as in ordinary buildings, or complicated, as in tall blocks or large bridges. The way the structure works can be expressed either for the structure as a whole or for the individual components. For bridges one would think that it would be natural to express the structural system, but older bridges do not necessarily do this, and even today beams may be camouflaged as arches or the cladding may hide the system. But even if it has been decided to express the structure, the design has only just begun and there are still numerous possibilities for the shape of the bridge. Buildings need not, of course, necessarily express the structure. Their function is generally complicated and other factors may be equally, or more, important, such as the plan, circulation, space, services or the envelope, which protects against the weather but may not necessarily be load-bearing. However, it is possible to express the structure as it has been attempted in tall blocks etc. - not always successfully.

Nervi has become renowned for his buildings with clear, clean and easily understood structure - although they are not necessarily easy to analyze. Where possible he separates the elements of the construction and deals with their shape individually. Even his shells are given rigidity in certain directions, making them appear like ribbed structures. Nervi is at his best on buildings where the structure can be expressed in a simple way. This is his speciality. In the Palazzo dello Sport in Rome he has expressed it internally only, and this building is not of the same high quality as the smaller Palazetto, which possesses the expression both externally and internally.

ANALYSIS

While dealing with the structural system it may be useful to consider the analysis and its importance. For a large and complicated structure it is essential to obtain as exact a knowledge as is possible of its forces, stresses and deflections. Some structures are easily analyzed, others are



Above: University of Sussex at Brighton in course of construction. Below: the completed building



more difficult. Many are impossible if reasonable agreement is required between calculated results and actual conditions. Engineers and mathematicians have long been engaged on shell structures and much progress has been achieved. Solutions of three-dimensional problems such as thick dams and anchorages for prestressing cables are now being attempted but much has to be done before shells are completely mastered and even then we are talking about shells of simple geometric shapes, which form only a small proportion of structurally possible shells.

The shell over the Smithfield Market in London is of a type which in one aspect at least, is impossible to analyze theoretically at the moment. The shape is quite simple, an elliptical paraboloid, rectangular on plan and supported along all four sides. It is 230 ft. by 130 ft., probably the largest in Europe. The shape is very flat, rising only 30 ft. from corner to top. Extensive calculations were required, comparatively simple as far as the stresses were concerned, but no satisfactory calculation could be produced to prove the stability. This was done by a model test which generally confirmed the concept, provided the edges were suitably prestressed. Due to this prestressing the membrane theory gave results very close to the bending theory.

UNDERSTANDING THE STRUCTURE

The use of computers has made possible much more extensive calculations than before, and many mathematicians maintain that simplified methods of calculation are no longer of value. However, the so-called exact methods are still based on doubtful assumptions such as homogeneous, ideal and isotropic materials. Thus the results are not necessarily as accurate as they are claimed to be. It is of greater importance to obtain an intimate understanding of the way the structure works, since only through this can the engineer use his creative imagination and ability to the full. The principle of shell construction is comparatively easy to grasp. Most of the double-curved shells carry their loads mainly through membrane forces, whereas for cylindrical shells the transverse moment, which helps to maintain the shape of the shell, is the deciding factor. This can easily be understood by dividing the shell into plates and considering the effect of the interaction between the individual plates. It is more difficult to envisage the effect of the edge conditions but these are generally of lesser importance for the shape of the shell. Even then it is possible to imagine the significance, for instance prestressing along the edges, etc. These simple considerations are more important for the concept of a whole class of structures than are mathematical calculations. The latter only give information about one structure under consideration. After deciding the shape, a more detailed analysis is generally necessary, but one should not conceive the structure with an eye to the feasibility of an analysis. Candela has obtained a most extensive experience and perfection in the understanding of shape through tests and observations of certain structural forms, such as hyperbolic paraboloid and other second-order surfaces. This has enabled him to build daring structures based on quite a simple analysis, which would probably be totally inadequate without his experience.

STRUCTURAL HONESTY

The understanding of how a structure works - as a whole or in part - is often made easier by drawing isostatic lines, either of direct forces or moments. Both Torroja and Nervi have been aware of this, and Nervi has expressed them directly in many of his slabs. This must be for purely aesthetic reasons, since structurally they seem of doubtful value. A much simpler form will be equally correct structurally and could perhaps even be said to be justified by the yield line theory.

The study of deformations rather than forces is very important for the intuitive understanding of the structure. This is particularly obvious in frameworks and will safeguard against many wrong assumptions in the formation of the mathematical model for the analysis. Not all structures are, of course, difficult to understand

and the most beautiful structures are perhaps those which are quite simple and clear in their expression and form. A structure can express the qualities of the materials, for instance, a concrete structure can appear as a monolithic whole, while a steel or timber structure may clearly show the component elements. The difference between steel and timber can be expressed in the joints. If laminated timber is used, the shape should be entirely altered, approaching concrete. Prefabricated concrete may be expressed in a way approaching steel and timber structures, but the joints would be different.

Prestressed concrete is a special problem. It can be considered either as a homogeneous material - and treated as steel - or as a special form of reinforced concrete - by considering its behaviour at failure. In the former case it should have a symmetrical cross-section, in the latter a compression zone. In the meeting hall of the Unesco Building in Paris, Nervi has attempted to express the function as well as the material by making the compression slab follow the shape of the moment diagram. In the concourse of the Sydney Opera House the same effect has been expressed in prestressed concrete by moving the walls in and out in accordance with the curve of the moments. This seems a more natural way although both can only be justified in special cases, where the economy is not of primary importance.

The architectural understanding of structures varies considerably. For bridges it generally coincides with the structural function, which is clearly the dominating factor. Also, in other cases the architect occasionally tries to show the function of the structure, for instance in power stations, water-towers, etc. But complicated buildings are difficult to express and often it is difficult to discover what has inspired the architect. Buildings can have an almost abstract sculptural appearance, as shown by le Corbusier, or they go to the other extreme, as seen in the severe and formal architecture by Mies van de Røhe. Both interpretations have little to do with structure, although it must be accepted that the architect's appreciation of structure often differs considerably from that of the engineer. The architect is not bothered by mundane things such as moments and shear stresses but considers only form and effect. He follows his intuitive concept and feeling for the structure. Structural honesty, if it means anything, is the expression of the structure as it works - possibly clarified and simplified to help immediate understanding. The justification of this in a complicated structure is debatable, and even if the idea originally were formed with the best intentions it is now often misused and misunderstood.

CONSTRUCTION AND FORM

In Sussex University, Sir Basil Spence has attempted to use the shell form aesthetically, but economic and other considerations prevented us from following him in the actual structure. The result was a prefabricated solution of beams and curved slabs. The question here is whether it is justifiable to use the form for its own sake, and if it creates the desired architectural effect it may be difficult to refute this. In the old days the problem did not exist. The architect and the engineer were one and the same person, or perhaps it is more correct to say that neither of them existed in the sense we know them now.

The method of construction can influence the form of the structure. As the structure can be expressed simply and clearly, so can the method of construction. The project for the Tay Bridge is an example of this and the development of the form of the Sydney Opera House shells illustrates both the simplified structural function and the influence of the method of construction.

The construction method can open further possibilities or result in more limitations for the structural concept. For shells the limitations are certainly more prominent than the possibilities, and these structures have a long way to go before they can achieve the freedom from analytical and constructional limitations. The aesthetic consideration of the details in a structure is very important. Certain considerations can guide the designer, but basically it is a

question of artistic ability and sensitivity. Nervi's work shows this great care for detail and the Durham Bridge clearly shows the method of construction but it is really the details which make the bridge.

Today we have materials which can do almost anything. This opens immense possibilities but also makes big demands. In the old days a structure could not help being right - otherwise it would simply have collapsed. Today an architect can do almost anything he likes on his drawing-board, and a clever engineer will nearly always be able to make it stand up. The eminent architect can make use of this whether he wishes to go for abstract or for concrete effect. But there are many dangers for the architect who is not quite in the top class, especially if he thinks he is. It is possible for an architect and an engineer, step by step, to achieve a solution which satisfies both. During this process the architect will gradually absorb the structural possibilities, whilst the artistically sensitive engineer will understand the ideas the architect has in mind. In a paper like this it is, of course, impossible to do more than just touch on a subject which one could and ought to write volumes about. The object is just to draw attention to a problem which is often neglected or perhaps even not understood.

University of Sussex - Crane lifting vault unit



Bootham School Assembly Hall

Edmund Happold and
Trevor Dannatt

I think the most satisfying building that our group worked on last year was an assembly hall for Bootham School in York. There are two reasons for this feeling. Firstly, my family have many connections with the school and I was a pupil there myself. Secondly, I found a great understanding and sympathy for what the architect was trying to achieve. And, by and large, I feel that he has achieved it. Bootham is a boy's boarding school in the centre of York. The buildings are predominantly Georgian and the site dominated by a superb view of York Minster. The school is run by the Quakers and so an assembly hall is not only used for school meetings, plays, etc. but also for Meetings for Worship - making it an equivalent to a school chapel. Anyone can speak at Quaker meetings, so that it is a centralized activity. The way in which the architect dealt with the problem is probably best described in his own words.

THE ARCHITECTURE - TREVOR DANNATT

In considering the design of the Hall, I was fortunate in receiving a clear brief which not only laid down detailed requirements but also indicated the critical architectural problem - that of designing a building of form and atmosphere appropriate to daily assembly and weekly meetings, yet capable of being transformed into one suitable for theatre and opera, as well as other public occasions - the scale of expression ranging from serenity to festivity. 'Dual-purpose' is characteristic of school-halls, but design for devotion often takes second place to design for drama. Indeed, there are countless halls, where, though drama is not the most frequent use, on all other occasions the assembled are in a space without significance, confronted by the negative and uninspiring blank of a curtained proscenium opening. This was the basic internal architectural task to be solved, apart from the general problem of architectural planning relating to stage and dressing-room provision, seating accommodation - indicated at about 320 for the floor and 150 for the gallery - crush-hall, cloaks, lavatory accommodation etc.

Considering siting, a position for the building had been suggested which appeared a good assessment and from studying the site, there was no doubt that the area suggested was the most suitable place whilst the wish to preserve a view of York Minster from ground level gave reason for not attaching the building to the fabric of the main school. However, there was a stronger reason for not doing this. From the outset, considering external form, it was felt that the assembly hall should be a free-standing building, placed so that it becomes the pivotal building to the whole complex of school building, as is appropriate to its use. Again it was felt that such a cardinal building should be architecturally distinctive, fully modelled and of strong, formal quality, analogous to a piece of free-standing sculpture in a courtyard.

The siting of the Hall expresses its importance. At the same time, the approach is not forced, being on a natural line from the main buildings. The entrances are on the south west corner, relating to the angle of approach and directional feeling is carried into the interior by means of the two-armed crush-hall, with entrances into the hall proper at the end of each arm. The ceiling of the crush-hall is formed by the stepped soffit of the gallery over, which also emphasizes movement into the building, and this is further expressed by the placing and shape of the stairs to the

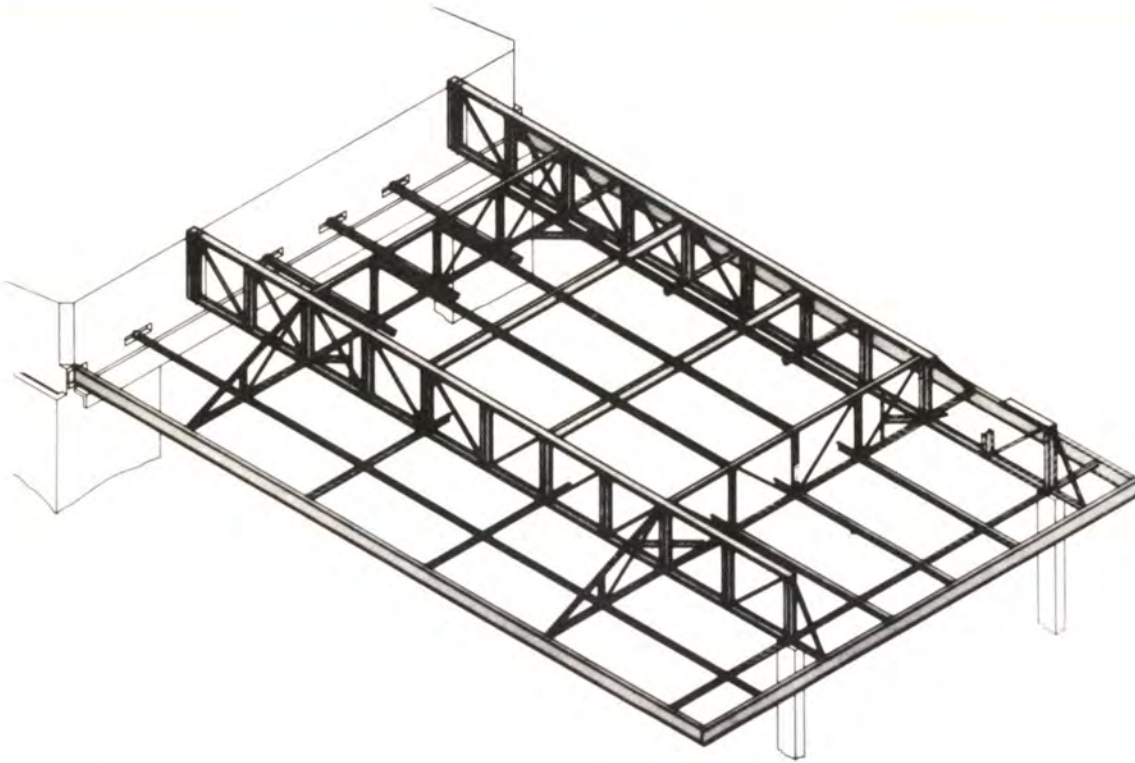

Bootham School Assembly Hall -
roof structure

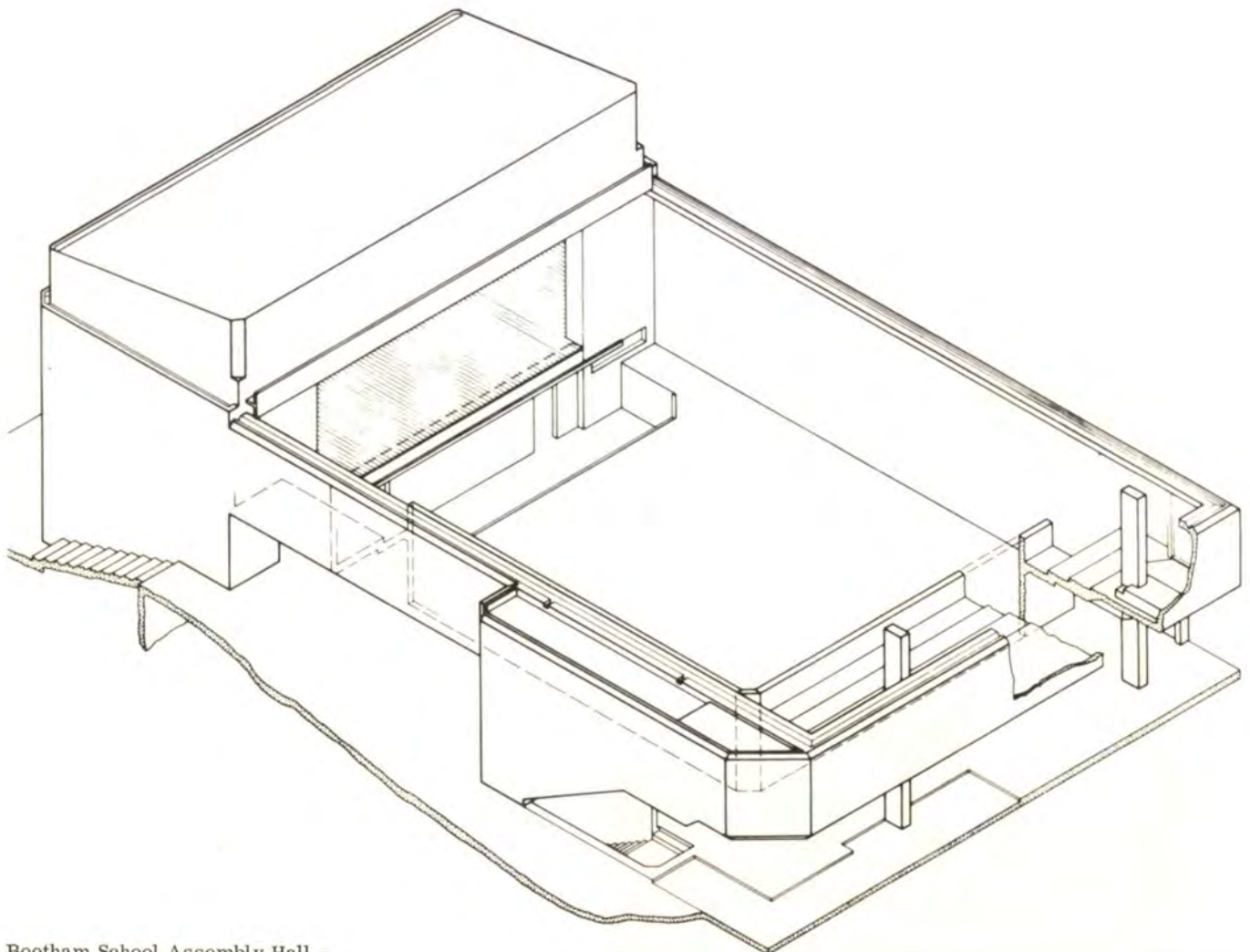

Bootham School Assembly Hall -
main structure



Above, below and bottom right: Three different aspects of Bootham School



gallery. The long axis of the hall is at right angles to the main front of the school and the stage is placed furthest away from the school, adjacent to the science building. This enables full use to be made of the fall of the site in the provision of dressing room and other accommodation beneath the stage, with the minimum of excavation. As already touched upon, the problem of the main hall was to create a dual-purpose space, where provision for less frequent, but more elaborate, occasions (theatre) do not detract from simpler, but more profound ones. Two opposing plan forms had to be resolved - focussed seating for worship, with tranquillity - assembly also needing this type of space. In essence, the central space is top-lit from four sides of a high clerestory over the seating area, formed on two sides by the walls that separate the crush-hall from the main hall and which carry up to form the gallery front - completed by a screen wall which stands in front of the stage curtains and opening, thus overcoming the unsympathetic background which stage curtains make when a hall is used for any purpose other than drama. The fourth side is the high, side wall of the building proper. For dramatic presentations, the screen wall is lowered into the floor and the natural toplight blacked out. Directional artificial lighting related to shallow recesses in the ceiling over the stage and at the gallery end will change the whole emphasis of the interior, making it appear more elongated and bringing the stage into prominence. Various arrangements can be made for different types of production, for example, conventional stage, stage with fore-stage and stage with orchestra pit. Of particular importance are the south and west aspects of the building, facing the main school and dining-hall, and on these sides the crush-hall is separated from the outside only by glazing, inviting entrance as well as commanding an outlook, in contrast to the closed quality of the hall itself. It is intended that sections of glazing could be opened on occasion, when the crush space would become particularly appropriate to special gatherings in the temperate part of the year, linking the hall itself to exterior terraces, extending on each side. These, combined with stairs from the lower level, complete the attachment of the building to the site, while new terracing proposed along most of the main school would assist the linking of the buildings into a whole, whilst enhancing the view towards York Minster.

**THE STRUCTURE -
EDMUND HAPPOLD**

The building is of reinforced concrete construction with a boarded finish and with a structural steel roof covered with wood wool slabs and copper. The roof was really the first part of the building we designed. The architect felt

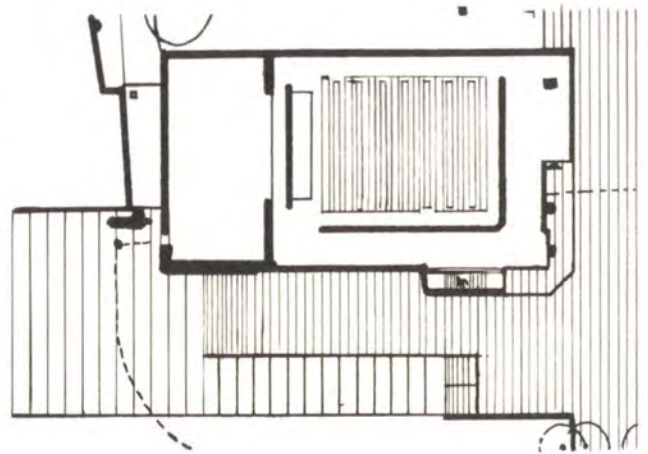

Position of the New Assembly Hall shown in conjunction with the N-W corner of the existing Science Block, i.e., the corner nearest to the School Playground

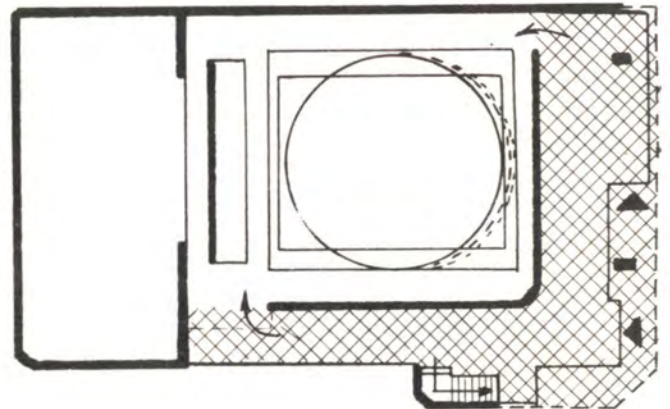

New School Hall, as used for Assembly and Meeting. Centralized space indicated symbolically by circle, with removable screen wall and stage to the left

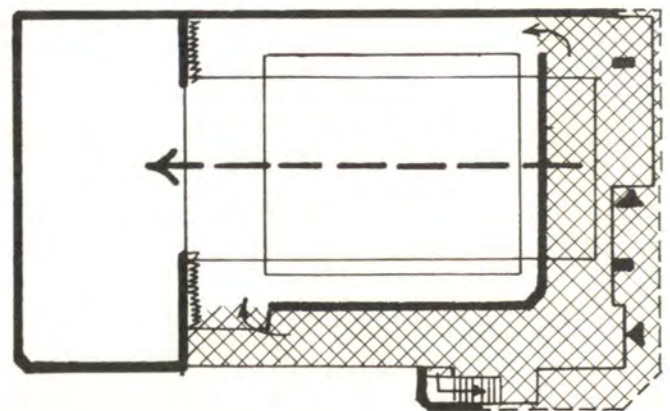

New Hall, in use as Theatre, with screen wall removed, and directional artificial lighting, focussing attention on stage as indicated by arrow.

that it was important, in order to be able to achieve a uni-directional feeling in the hall related to the stage and a centralized feeling related to worship, to form a higher central roof with clerestory lighting right round it. He wished the hall itself to have no columns through it so it would have meant a roof, as shown in scheme 1, supported only round the perimeter (Diagram below). At our first meeting we rather dissuaded him from this, but on further thought, got quite steamed up about forming it as a free form slab with steel tubes. Unfortunately, by the time we next met the architect, he had come round to our previous position and wanted to carry out scheme 2. This scheme meant two main trusses running down the building supported on the stage tower at one end and on two columns at the other. Two secondary trusses supported the high roof and the two sides of the low roof cantilevered off the main trusses and had no supports at the perimeter. Basically this is the structural system finally used.

For lighting reasons the main trusses are oversized in height and the tension and compression members are formed of channels. In order to take the cantilever, the verticals were made of universal columns, of the same width as the channels, which had moment connections into the cantilever beams and into the upper roof beams. The diagonals are of round tubes.

We were not entirely happy with the cantilevering beams as we felt the deflection of the edge beams would be excessive. On explaining this to the architect he agreed to having hangers at the ends of the secondary trusses. We felt it made the roof read more structurally and that is how it is

built. And it looks very impressive seen from the stage inside with the entire perimeter clear and just two slim columns supporting the roof.

We were rather worried about the risk of corrosion to the steel-work so we tendered three alternative finishes to it. These were:

- a) Galvanizing
- b) Zinc spraying
- c) Zinc silicate paint

We have done this before for steelwork and galvanizing has always been the cheapest but this time grit blasting and zinc silicate painting were the cheapest. Zinc silicate surface coating behaves in a similar manner to the other two metallic zinc coatings with the advantage that it requires less expensive equipment to apply and if necessary, can be applied on site.

The other interesting part of the structure is the cantilevered balcony. The parapet wall to the balcony is carried down to the floor to form the support to one side. The other edge of the balcony is carried by the external wall acting as a deep beam which, in turn, is picked up on two cross-beams which run through the roof support columns to the parapet wall. Round the corner, the side wall to the stair acts as a pivot, the tensile force from the cantilever being taken out by the concrete roof to the stair and, in turn, transmitting it to the beam wall running down the side of the building. From the beam wall the force is taken to the foundations by the side wall to the stage tower. The contractor said he believed it. He just would not strike it until someone from our office was present.

Scheme 1

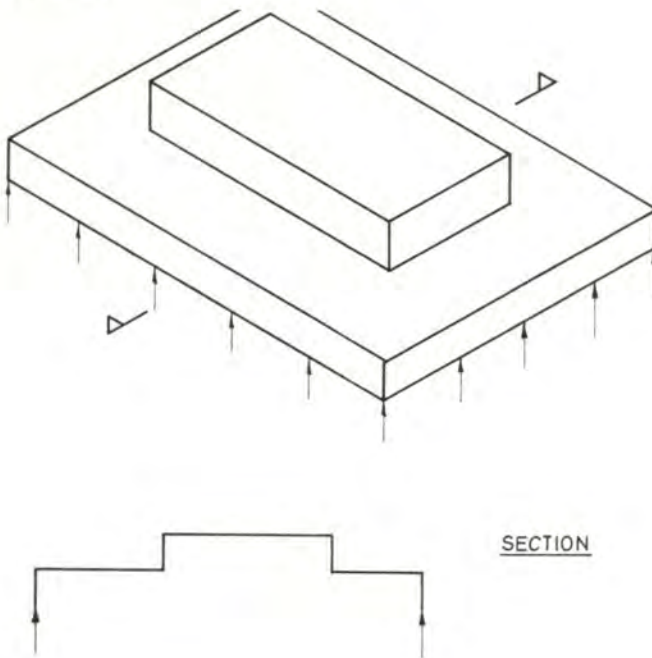

Scheme 2

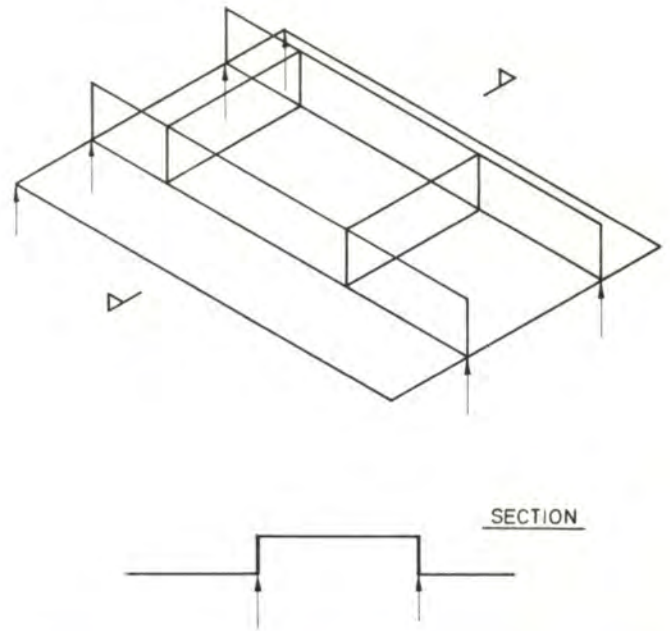

Recent additions to the library

Journals and proceedings of societies are not included.

The publications listed are classified by the Universal Decimal Classification System.

Reference Books - Engineering 03:62

ESHBACH, O. W. Editor. Handbook of engineering fundamentals; 2nd edition. Wiley, 1963. £5 8 0

NEWNES Engineers Reference Book; 10th edition. Newnes 1965. £6 0 0

Reference books - modern architecture 03:72.036

TAYLOR, N. Cambridge new architecture; a guide to the post-war buildings; 2nd revised edition. The Editors of 'Cambridge New Architecture', 1965. 7/6

Dictionaries 03.08

BIRCHON, D., Dictionary of metallurgy. Newnes, 1965. £2 5 0

HAMMOND, R., Dictionary of civil engineering. Newnes, 1965. £1 16 0

JACKSON, K.G., Dictionary of electrical engineering. Newnes, 1965. £2 5 0

TAYLOR, J.L., A Portuguese-English dictionary. Harrap, 1959. £3 15 0

Report writing 047

WILKS, H.M., Report writing and proofs of evidence; 3rd edition. The Estates Gazette Ltd., 1964. £1 5 0

Statistics 31

BULMER, M.G., Principles of statistics. Oliver and Boyd, 1965. £1 15 0

Research 5.001.5

NOLTINGK, B.E., The art of research; a guide for the graduate. Elsevier, 1965. £1 10 0

Geometry 513

PRENOWITZ, W. and JORDAN, M. Basic concepts of geometry. Blaisdell Publishing Co., 1965. £3 0 0

Trigonometry 514

PAGE, A., Trigonometry; for the use of higher forms in schools and university students. University of London Press, 1962. £1 0 0

TOPPING, J., Plane trigonometry. Longmans, 1962. 14/6

Calculus 517

BAKER, C.C.T., Introduction to calculus. Newnes, 1965. £1 1 0

Differential equations 517.9

MURPHY, G.M., Ordinary differential equations and their solutions. Van Nostrand, 1960. £3 6 0

Corrosion 620.193

UHLIG, H.H., Corrosion and corrosion control; an introduction to corrosion science and engineering. Wiley, 1964. £3 15 0

Civil engineering 624

BOAGA, G. and BONI, B., The concrete architecture of Riccardo Morandi. Tiranti, 1965. £4 10 0

Theory of structures 624.04

MILLS, G.M. The theory of structures. Macmillan, 1965. £1 17 6

TIMOSHENKO, S.P. and YOUNG, D.H. Theory of structures; 2nd edition. McGraw-Hill, 1965. £5 16 0

Wind pressure 624.042.41

NATIONAL PHYSICAL LABORATORY. International conference on wind effects on buildings and structures, June 1963. HMSO, 1965. 2 vols.

Frames 624.072.33

KLEINLOGEL, A. Rigid frame formulas. Crosby Lockwood 1958. £4 10 0

PARKES, E.W., Braced frameworks; an introduction to the theory of structures. Pergamon, 1965. £1 1 0

Space frames 624.074.8

MAKOWSKI, Z.S., Steel space structures. Michael Joseph, 1965. £3 5 0

Soil mechanics 624.131

INTERNATIONAL CONFERENCE ON SOIL MECHANICS

AND FOUNDATION ENGINEERING. 6th MONTREAL, 1965. Vols. 1 and 2. University of Toronto Press, 1965.

Foundations 624.15

CARSON, A.B. Foundation construction. McGraw-Hill, 1965. £6 8 0

Piles 624.154

MICHIGAN STATE HIGHWAY COMMISSION. A performance investigation of pile driving hammers and piles. The Commission, 1965. \$5.00

Bridges 624.2

HENRY, D. and JEROME, J.A. Modern British bridges. C.R. Books Ltd., 1965. £3 3 0

Curves - road 625.7

IVES, H.C. Highway curves; 4th edition. Wiley, 1964. £3 0 0

Traffic engineering 656

DAVIES, E. and CASSIE, W.F., Editors, Traffic engineering practice. Spon, 1964. £3 15 0

Road safety 656.1.05

ROAD RESEARCH LABORATORY. Research on road safety. HMSO, 1963. £2 2 0

Computers 681.14

HERSEE, E.H.W. A simple approach to computers. Blackie, 1964. 12/6

Slide rules 681.143

BLAINE's the slide rule as an aid in calculating, edited by A.T.J. Kersey; 7th edition. Spon, 1952. 10/6

Technical notes issued by Ove Arup & Partners

Titles marked (A) in the right hand margin are still topical and of general interest. Titles marked (B), whilst not 100% up to date are well worth studying as an introduction to their subjects. Titles marked (C) are obsolete, superseded or of very limited interest.

No. 1 (C)
Foundations: notes on site investigations before design of foundations, by R.W. Hobbs, 1956

Supplemented and amended March 1961 by Technical Note No. 25, which in turn will be superseded.

No. 2 (A)
Design of continuous concrete beams and slabs by the method of partial fixity, by P. Beckmann and P. Dunican

Simple method of 'plastic' design which avoids moment distribution and leads to reduced support moments.

No. 3 (B)
Shear in flat slabs without drops: preliminary report, by G. Trimble and P. Dunican, 1962

Provisional recommendations for shear reinforcement.

- No. 4 (A)
The Danish method of column design, by P. Dunican and P. Beckmann, 1958
- Describes a method whereby the effect of fixing moments from beams and slabs framing into the column is allowed for as a percentage increase of the axial load
- No. 5 (C)
Building Act requirements within the L.C.C. area for the design of free-standing reinforced concrete chimneys, by J. F. Lancaster, 1958
- Incorporated in new L.C.C. (now Greater London Council) London Building Acts 1930-1939; constructional bylaws with explanatory memorandum. L.C.C., 1965
- No. 6 (C)
Copy of Section 4 of the Timber Development Association (sic!) Draft Production Standard for Structural Glued Laminated Timber, 1958
- Incorporated in the Timber Research and Development Association's 'Production standards for structural glued laminated timber, 1959'.
- No. 7 (B)
Notes on the calculations and design of deep beams, by A. J. J. Bartak, 1959
- The theory of the stress distributions in deep beams, design formulae and tables for elastic analysis and design data allowing for cracking of the concrete.
- No. 8 (C)
Cased stanchions, by A. J. J. Bartak, 1959
- Methods for including the strength of the fire protective concrete casing in the load carrying capacity of the stanchion.
- Covered by BS 449 (1959)
- No. 9 (B)
A method of design of precast, spiral stairs, by A. J. J. Bartak, 1959
- Chiefly describes the equilibrium analysis of the spine column
- No. 10 (C)
L.C.C. strength and stress requirements for special concrete mixes, by A. J. J. Bartak
- Corresponds to CP 114 (1957) Covered in L.C.C. (now Greater London Council) London Building Acts 1930-1939; Constructional bylaws with explanatory memorandum. L.C.C., 1965.
- No. 11 (C)
The concrete in sulphate bearing soils, by A. J. J. Bartak
- The nature of the attacks of the different sulphates on concrete, the resistance of the various available cements and recommendations for preventive precautions. Recent test information, however, disputes the virtue of 'Supersulphated' Cements. To be superseded by Technical Note No. 37.
- No. 12 and No. 13 were never issued.
- No. 14 (B)
Use of cement retarders, by A. J. J. Bartak, 1959
- Methods of using retarders in various applications with special reference to 'Redalon', critical review of the advantages claimed by the manufacturers and warning that permanent loss of strength does occur to a certain depth.
- No. 15 (C)
A review of current practice for protection of structural steelwork exposed to atmospheric action, by A. J. J. Bartak, September 1959.
- Superseded by Technical Note No. 32
- No. 16 (B)
Deflections of reinforced concrete slabs, by A. J. J. Bartak, November 1959.
- Describes the contributions of the elastic properties, creep and shrinkage to the total deflection and provides methods of calculating these effects separately and combined.
- No. 17 (C)
Concreting in cold weather, by A. J. J. Bartak, January 1960
- Evaluates the danger of frost damage to concrete placed in different positions under varying weather conditions and sets out recommended practices.
- Superseded by Technical Note No. 38
- No. 18 (A)
Surface foundations in areas of the British Isles, with seasonal ground movement, by C. Romhild, December 1959
- Describes the mechanism of frost heave shrinkage and swelling. Sets out soil properties which predispose to these movements and give recommended precautions.
- No. 18A
Damage due to frost heave with particular reference to cold store design, by P. L. Campbell. February 1960
- Supplements to No. 18 with regard to cold stores etc. and gives literature references.
- No. 19 (C)
Report on the American Concrete Institute's 'Tentative requirements for thin-section reinforced precast concrete construction', by A. J. J. Bartak. February 1960.
- The ACI have issued '525-63-ACI Standard minimum requirements for thin-section precast Concrete Construction'. These supersede this note.
- No. 20 (B)
Notes on the use of steel tubes for structural engineering, by J. N. Martin, April 1960.
- Summary of three day course given by Tubewrights Ltd. in February 1960
- A good and necessary introduction to design of structures made of steel tubes. The data are out of date and rectangular hollow sections are not included.
- No. 21 (A)
Screeds for flat roofs, by J. A. Waller, March 1960
- Outlines the problems due to trapped moisture and condensation in insulating screeds and gives some facts on effective prevention in the form of no-fines screeds and ventilated gas-concrete insulation.
- No. 22 (B)
Report on symposium on fatigue of welded structures, by A. Stevens, May 1960
- Whilst appearing slightly confused because of reporting separate contributions, this contains information on the nature of fatigue problems, cures and prevention which is useful as a starting point for further study.

- No. 23 (A)
Bricks - results of tests (in accordance with Bylaw No. 19).
May 1960
- A list of bricks stating trade name, type, colour, crushing strength and grade according to L.C.C. bylaws.
- No. 24 (B)
The characteristics of high tensile strand and its use in prestressing, by P.D.Skead, October 1960
- Report on symposium giving a general idea of mechanical properties, stressing systems and practical points affecting construction work.
- No. 25 (B)
Supplement to Technical Note No. 1, by C.Romhild, March 1961
- Planning and administration of site investigations with sample tender documents.
- To be superseded.
- No. 26 (A)
Wind pressures on buildings and towers, by J.G.Nutt, March, 1961
- The theoretical and experimental background for determination of design wind forces on tall structures not covered by existing (January 1965) Codes of Practice and bylaws. (London District Surveyors now go by the L.C.C. (now Greater London Council) - London Building Acts 1930-1939; Constructional bylaws with explanatory memorandum. L.C.C., 1965) See also Technical Note No. 31
- No. 27 (B)
First International Conference on timber engineering, held at Southampton University, 18-23rd September, 1961 (Report) by R.F.Marsh. February 1962
- Report on conference highlighting the main innovations and construction trends discussed.
- No. 28 (A)
Flat slabs designed according to British Standard Code of Practice CP 114 (1957) by P.Dunican, April 1962
- States that, as the empirical method in CP 114 (1957) results in minimum structural cost, it should be used whenever possible.
- No. 29 (A)
Slab design by the yield line theory, by O.Bjarkild, August, 1962
- Partly a translation of K.W.Johansen's 'Pladeformler', it contains formulae for frequently occurring shapes of slabs with varying support conditions together with several important design considerations which are not immediately obvious from Johansen's yield line theory.
- No. 30 (B)
Report on the use of an epoxy and a polyester resin for fastening standard metal fixings to concrete, by P.Hone. March 1963
- Lists the ideal properties of a resin for the purpose, describes the test procedure and the modes of failure, including 'delayed brittle failure'. Discusses mechanical surface preparation, but does not include chemical cleaning. Further tests have since been carried out on the Sydney Opera House and experience from there should be consulted.
- No. 31 (B)
Report on the International Conference on Wind Effects on buildings and structures (26-28 June, 1963) by P.Hone, 1964
- Discusses the main themes raised at the Conference and particularly the implications of J.G.Nutt's proposed design method (see Technical note No.26). Touches on alternative proposals and discusses oscillations caused by gusts and steady winds as well as the statistics involved in choosing a recurrence period.
- No. 32 (A)
Protection of exposed structural steelwork, by T.O'Brien, February 1965
- Supersedes Technical Note No. 15
- Full details of types of paint, methods of protection, information for different types of surface and particular attention paid to exposed steelwork.
- No. 33 (A)
Initial comments on the new Codes of Practice CP 114 and CP 116, by P.Beckmann. March 1965
- Preliminary observations on the new codes.
- No. 34 (A)
Chlorinated rubber paints, by T.O'Brien. May 1965
- General description of chlorinated rubber, its characteristics in paints and uses on various surfaces. Appendix: Report on visit to the works and laboratories of Allweather Paints Ltd.
- No. 35 (A)
Mastics and sealants, by T.O'Brien. June 1965
- Giving information on joint sealing materials, joint design and, as appendices, sealant costs and sealant manufacturers.
- Supplement No. 1 - issued December, 1965 giving more authoritative information on polysulphide sealants - i.e., which to use.
- No. 36 (A)
Lifting appliances for heavy loads in construction (excluding cranes), by J.M.D.Anderson, June 1965
- Detailed information on jacks, blocks and tackles, winches with costs of hire, lift height and maximum load.
- No. 37 (A)
Cement Manual, by T.O'Brien. Spring 1966 (to supersede and include Technical Note No. 11)
- The nature and properties of the hydraulic cements other than ordinary Portland cement and the conditions in which they are used.
- This is still in preparation.
- No. 38 (A)
Concreting in cold weather, by T.O'Brien and J.M.D. Anderson. December 1965
- This supersedes Technical Note No. 17
- No. 39 (A)
Hot weather concreting, by J.M.D.Anderson, 1966
- Still in preparation
- No. 40 (A)
Additives for concrete, mortars and grouts, by T.O'Brien 1966
- Still in preparation.



THE ROYAL
INSTITUTE OF
BRITISH
ARCHITECTS
INCORPORATED
1837-1887