

The Arup Journal

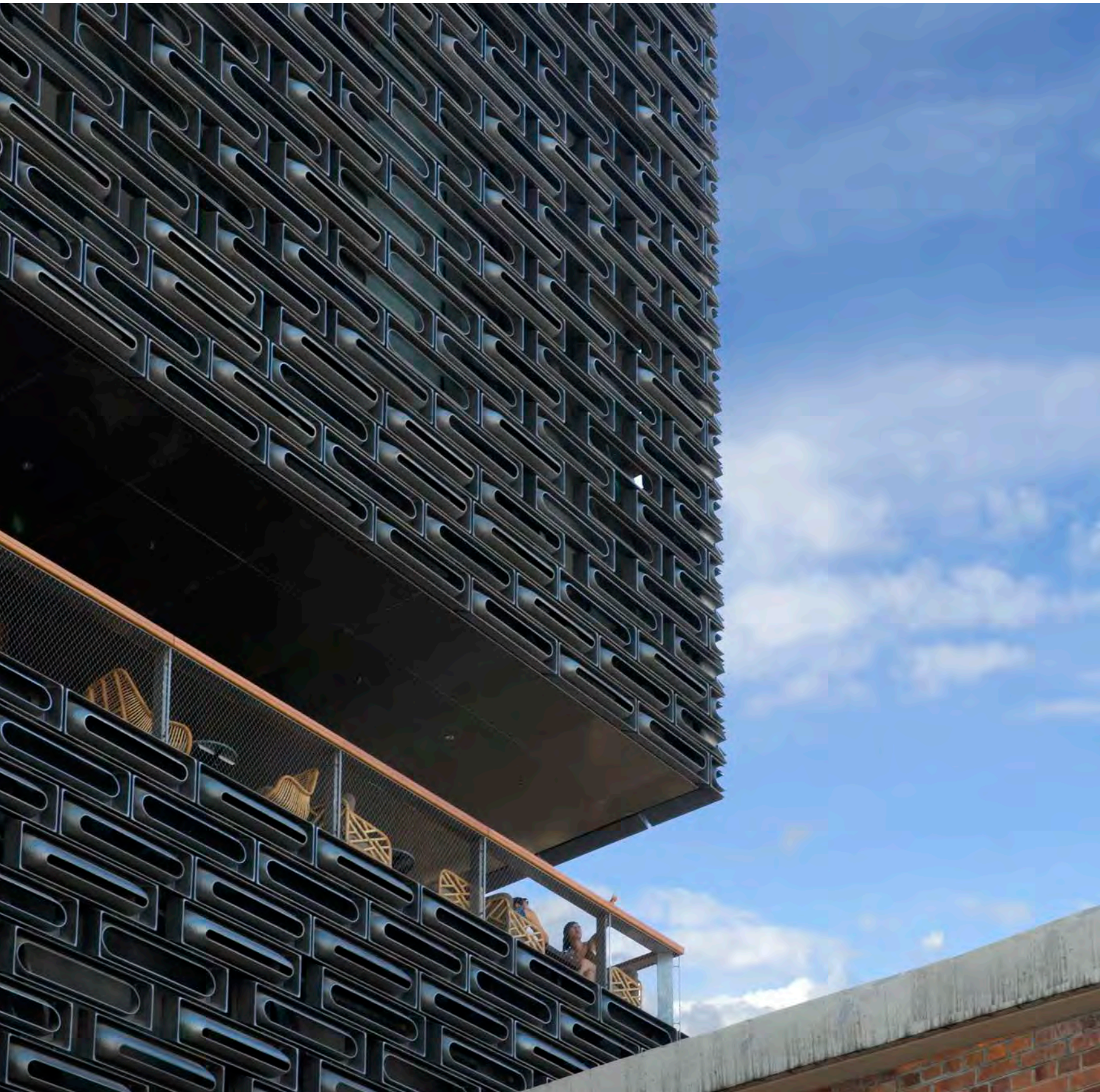

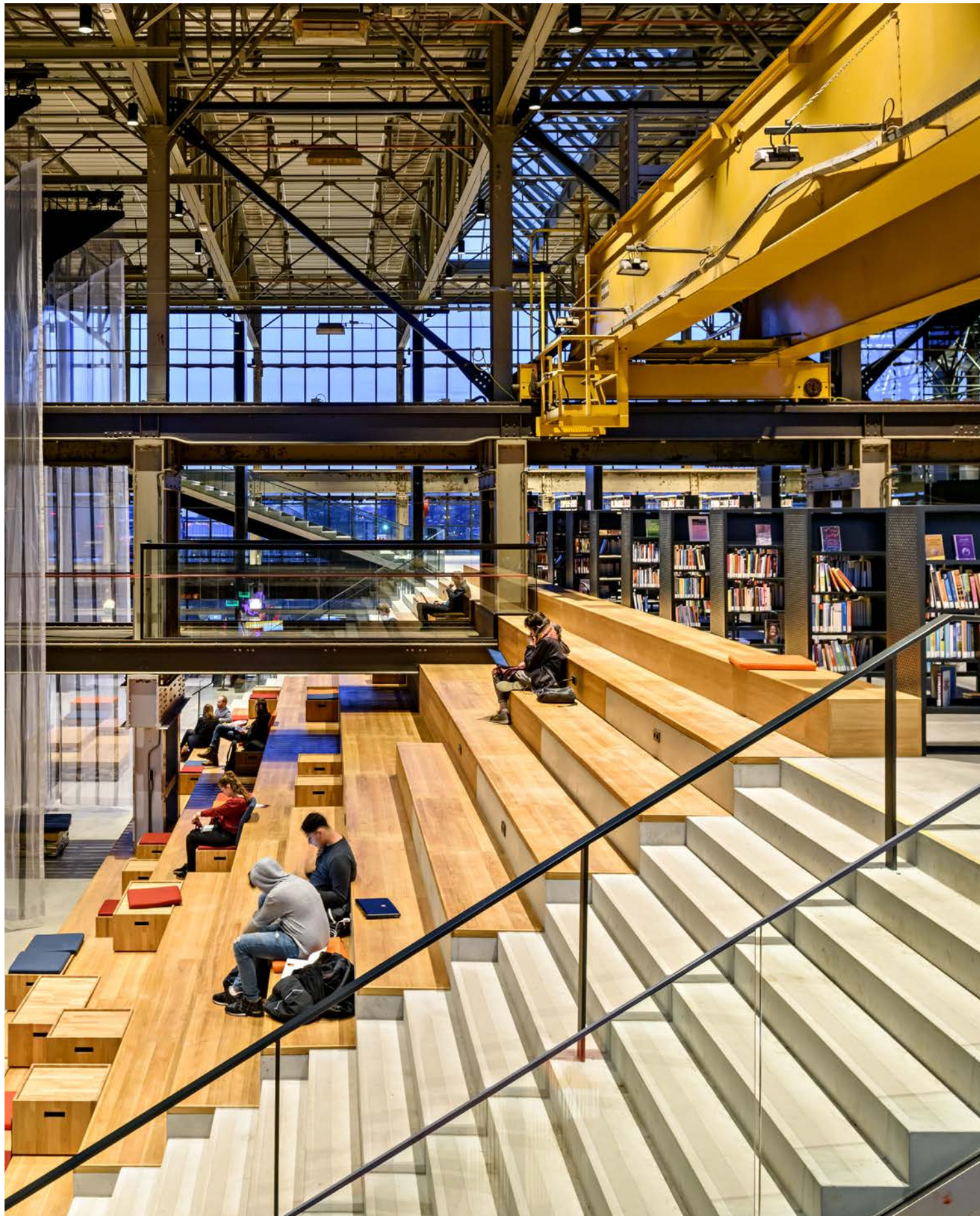

Contents



- 4 Tai Kwun, Hong Kong**
 Preserving heritage in a busy metropolis
 Florence Lam, Andrew Lawrence, James Sze, Paul Tsang, Young Wong, Gabriel Yam, Nina Yiu



- 34 O-PARK1, Hong Kong**
 By converting food waste into energy, this plant helps to create a healthier future for Hong Kong
 David Pegg, Michelle Shun



- 14 UNSW Science and Engineering Building, Sydney, Australia**
 Creating a world-class space for science and the arts
 Rob Fleury, Ben Moore, Andrew Pettifer, Stefan Sadokierski



- 40 Harvey Milk Terminal 1, SFO, San Francisco, USA**
 Sustainability was built into every step of this major terminal expansion
 Raj Daswani, Raphael Sperry, Byron Thurber



- 20 The Christie Proton Beam Therapy Centre, Manchester, UK**
 A safe and welcoming cancer treatment centre has patients foremost in mind every step of the way
 Nick Ashby, Hywyn Jones, Dave Pitman



- 48 Connswater Community Greenway, Belfast, UK**
 Providing flood protection while developing improved green spaces for the local community
 Carol Andrews, Chris Caves, Reuben Lucas



- 28 LocHal, Tilburg, Netherlands**
 A once-empty former industrial space has been rejuvenated as a gathering place for the entire community
 Simone Collon, Rob Verhaegh, Babette Verheggen, Mathew Vola

LocHal, Tilburg, Netherlands: Arjen Veldt Fotografie



1.

Changing of the guard

A Hong Kong landmark has been respectfully renovated and given a new lease of life and purpose

Authors Florence Lam, Andrew Lawrence, James Sze, Paul Tsang, Young Wong, Gabriel Yam and Nina Yiu

Tai Kwun, the Centre for Heritage and Arts, is Hong Kong's largest ever historic building revitalisation project. Arup was instrumental in transforming the city's former Central Police Station compound, with its 170 years of history, into a new cultural centre. Refurbishment projects are not common in a city where land is precious, with old buildings typically demolished to make way for new developments. Standing in sharp contrast to the surrounding commercial towers in the Central District, this revitalisation provides a rare publicly accessible 'courtyard' in the middle of one of the densest cities in the world.

Tai Kwun, or Big Station, was the compound's colloquial name and it was retained as a reminder of the site's former usage and its historical importance. Led by The Hong Kong Jockey Club, in partnership with the Government of the Hong Kong Special Administrative Region, the project included the conservation of 16 buildings on the site, which collectively form three declared monuments (the former Central Police Station, the former Central Magistracy and Victoria Prison), and the addition of two landmark buildings designed in collaboration with architects Herzog & de Meuron.

Arup's involvement in the project began in 2007. The firm provided multidisciplinary engineering services for the transformation

of the site including structural, civil and geotechnical engineering, and façade, lighting, fire, materials and security consultancy. Through seamless collaboration between Arup's local team in Hong Kong and conservation experts from the London office, along with specialist conservation architect Purcell and the local approval authorities, the unique historic buildings were successfully retained, repaired and strengthened for adaptive reuse.

Material investigation

The Tai Kwun site is home to some of the oldest surviving buildings in Hong Kong. Constructed using traditional Chinese materials (grey bricks and roof tiles) and materials imported from overseas (red bricks and timber), and using British building techniques, it is an early example of the two cultures coming together. The Barrack Block was constructed in 1864, the Magistracy in 1914 and the Police Headquarters was built five years later. The challenge for the project team was to preserve the heritage buildings on the 14,500m² site, making them accessible so they could be used for entirely new purposes and ensuring that they met modern building standards.

With no record drawings or construction information about the existing buildings, Arup's team of structural engineers and material specialists conducted an initial survey in 2009 to determine the structural



2.

1: Formerly Hong Kong's Central Police Station compound, Tai Kwun is now a centre for heritage and arts
2: Tai Kwun's Barrack Block was constructed in 1864. Police officers were trained here

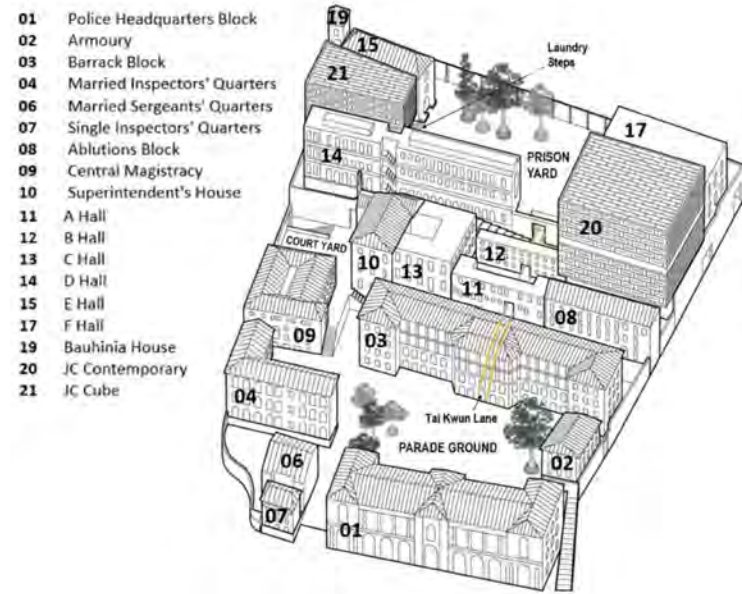

3. form, condition and material strength. The firm worked with the Hong Kong Antiquities and Monuments Office on agreeing the details of the opening-up works during these investigations.

Arup's London office provided invaluable advice on the properties and treatment of the historical materials such as brick, timber and cast iron. A rigorous procedure for the material testing and data analysis was established, taking into account the buildings' heritage status. The number and locations of the material samples taken for testing were chosen carefully so that they would deliver sufficient data for the statistical analysis while minimising the damage to the building fabric. The data gathered was checked for statistical outliers before being processed to deliver characteristic strength values for use in assessment calculations. This is believed to be the first time this statistical approach has been used to demonstrate meeting the statutory

requirements for the adaptive reuse of heritage buildings in Hong Kong.

During the investigation, an unusual type of reinforcement was discovered within the concrete floor slabs in the Police Headquarters Block and the Central Magistracy: two 5mm-diameter wires were twisted into a mesh within the concrete. At the material testing laboratory, samples of this twisted wire reinforcement were demonstrated to have similar tensile strength to modern reinforcing bars. Using a 'first principles' engineering approach, combined with statistical analysis of the test data and appropriate design factors, Arup proved the technical viability of reusing the existing slabs to avoid extensive strengthening or recasting of the floor slabs. In the Police Headquarters Block, 80% of the floor slabs were retained, with replacement required in just two rooms – these were in heavily loaded areas where new plant equipment was to be located.

Adaptive reuse

As most of the existing structures were constructed prior to the development of building regulations, it was inevitable that Arup's assessment approach would lead to some structural enhancement in order to meet modern design codes. The critical principle during restoration was to salvage and reuse existing materials where feasible and, in line with the conservation management plan developed for the site, to minimise structural intervention as much as possible. The methodology adopted meant that most of the building's historical fabric, including granite blocks, floor tiles, ironmongery, facing bricks, and timber doors, windows and floorboards, were salvaged and reused.

Since refurbishment is not common in Hong Kong, the collaboration with the local authorities provided a benchmark for subsequent refurbishment projects and

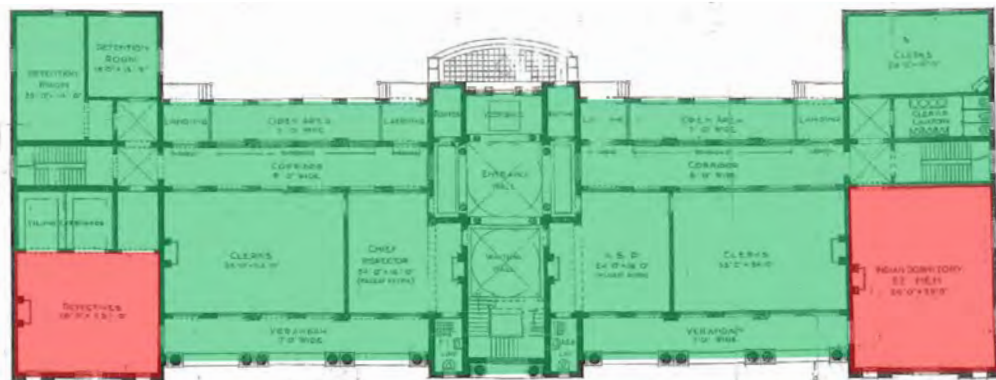

5. The revitalisation included conserving 16 buildings on the site and adding two new buildings (20 and 21)

6. Arup found wires 5mm in diameter twisted into mesh within the concrete in the Police Headquarters Block and Central Magistracy

7. Arup retained the buildings' original structure and materials where possible, but devised replacements where structurally necessary (new floor slabs shown in red)

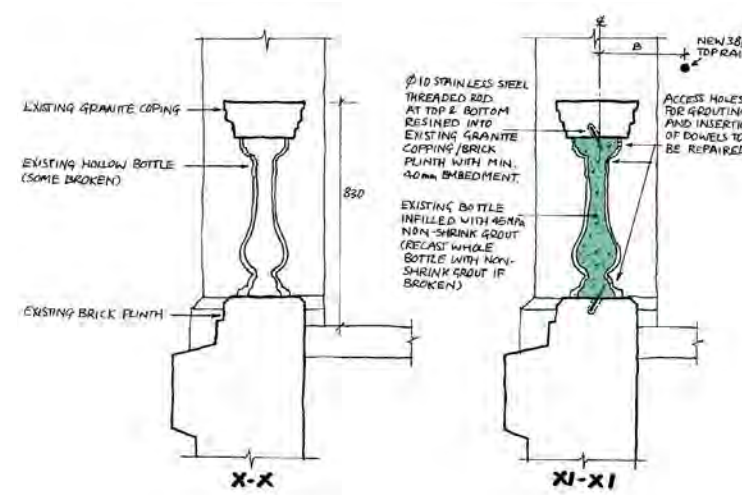

6. The hollow balustrade bottles were strengthened to comply with safety regulations by infilling with grout

7. The reinforced balustrades were load tested to code requirements

8. Arup designed steel arches to structurally enhance the historical brick archways

9. The steel arches provide minimal visual obstruction, showing only thin edges



7. The reinforced balustrades were load tested to code requirements

for the methods used to assess materials utilised in constructing historical structures in the city. The experience gained during the project is being fed into the next edition of the Hong Kong Buildings Department's *Practice Guidebook for Adaptive Re-use and Alteration and Addition Works to Heritage Buildings*, due to be released towards the end of 2020.

Barrack Block

When first constructed, the 19th-century Barrack Block had three storeys, with a further floor added in 1905. The block was originally used as dormitories for the police; in its new use as the visitor centre, which contains retail and restaurants, it has to accommodate increased loads. To avoid oversteering the brick walls, the building was retrofitted with a steel frame constructed on new foundations. The floors and roof were strengthened to provide better restraint to the walls under wind loading. This approach allowed the entire structure to be retained.

A veranda runs along the length of each of the upper three storeys of the block's north façade. These are bordered by bottle balustrades, which are a prominent visual element of the building and can be seen from the parade ground below. As an important heritage aspect, it was critical to the refurbishment that the balustrades be retained. However, the structural capacity of the balustrades, the wide gap between the bottles (greater than 100mm) and the low overall balustrade height meant they did not comply with safety regulations. The easiest option would have been to install glazed panels behind the balustrades, but this was rejected because the glass would have caused

reflections that would destroy the integrity of the historical fabric. The solution was to strengthen the hollow bottles by infilling them with grout, doweling the infill at the top into the existing granite coping and into the brick plinth at the bottom. Solid steel rods 22mm in diameter were added between the bottles and a 38mm-diameter solid steel top rail installed. The system was load tested to the current code requirements, allowing the upgrading works to gain statutory approval.

Recycling timber elements

Timber elements including doors, windows and floorboards were salvaged and reused where possible. The door leaves and window casements were dismantled and sent off site



8. Arup designed steel arches to structurally enhance the historical brick archways

for repair. Surface paint was removed and damaged portions (due to dampness or termite activity) were replaced by timber with an equivalent strength grade. Paint was then applied for decoration and protection.

The timber floorboards were removed, repaired where possible and returned to site for reinstallation, after which their surfaces were sanded and protective painting applied. The floors were upgraded to meet the required one-hour fire resistance rating using fire-rated board, with the structural capacity of the existing timber floor joists checked using the British Standard for structural use of timber and verified by in-situ proof load tests. In retail areas, further steelwork was

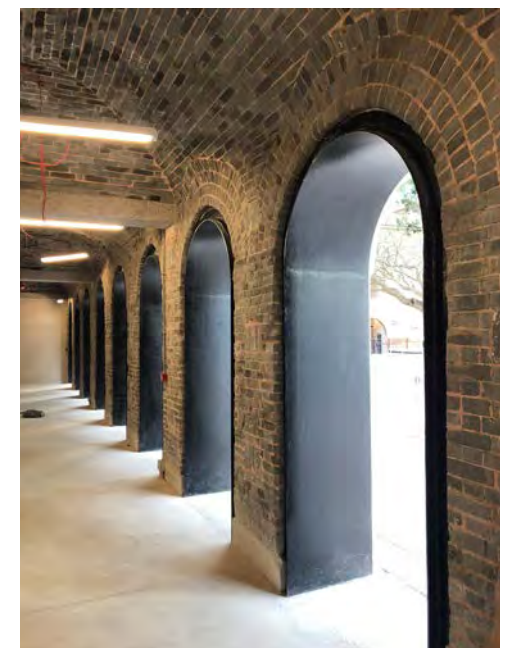

9. The steel arches provide minimal visual obstruction, showing only thin edges

added, spanning between walls to facilitate the fixing of tenant services, therefore avoiding the need to fix into the existing timber. Overall, 60% of the timber doors and windows were reused, with 25% of the timber floorboards salvaged, repaired and re-laid.

Prison buildings

In the west wing of the prison's D Hall, there is a significant surviving portion of the former radial prison completed in 1862. The ground floor was originally designed for larger cells, before brick walls were added to create smaller separate cells. To restore the open-plan layout, the lateral stability of the building had to be enhanced, so at the first-floor level Arup devised a new diaphragm structure that spans between the gable walls. This involved carefully lifting the existing granite flagstones, adding a horizontal truss made of flat steel bracing and recasting the existing screed in the cell areas with a 100mm-thick reinforced concrete slab. Once completed, this enhancement work was entirely concealed.

The ground floor features an elegant space consisting of a brick vaulted ceiling and an

arched colonnade. Assessment of the arched brick piers determined that structural enhancement was required in order for them to deal safely with elevated working stresses. To minimise visual obstruction of the original brick vaulted ceilings, Arup designed steel arches that were inserted into the arched openings. The steel arches were fabricated using 10mm curved plate welded to recessed ribs. These serve as an alternative load path and transfer the weight of the elevation to the foundations. Visually, the steel arches appear as 'door frames' with thin visible edges.

Prior to the police station being decommissioned, D Hall's east wing had suffered significant damage due to settlement caused by construction activities nearby. Furthermore, intrusive strengthening works had previously been carried out, with the addition of an external steel frame and horizontal 32mm-diameter tie rods tying the building. The façade had been partially patched up with cement and had significant cracks (some in excess of 100mm). As part of the refurbishment, Arup's Geotechnical team assessed the settlement and designed a solution to stabilise the ground below the building. In order to fill the voids in the

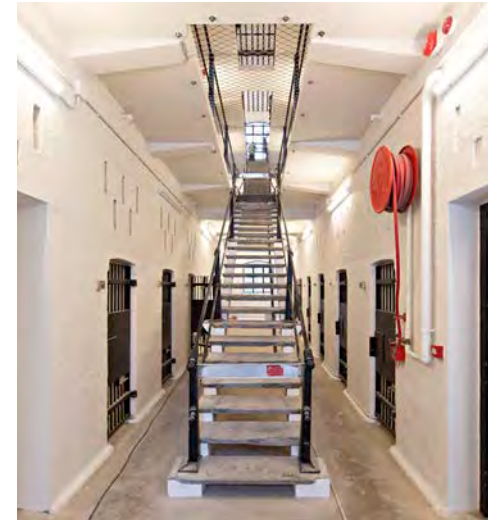

11.

soil and enhance ground carrying capacity, the ground was grouted using microfine cement injected under pressure to depths of between 3m and 6m below the existing granite footings.

Canopy, cantilever staircases and clay tiles

The canopy on the front of the Central Magistracy Building was in poor condition and opening-up works revealed that the support ties had deteriorated considerably. With the agreement of the local authority, the canopy was removed and replaced with a replica canopy consisting of a lightweight steel frame with a concrete screed. A spreader beam behind the façade anchors the canopy to the building's first-floor slab. A glass fibre reinforced concrete mould was used to ensure the new canopy visually matched the original.

The existing clay tile roofs on the buildings were refurbished. Initially, these were removed to allow renovation of the timber roof trusses, with new insulation and a vapour barrier added before the tiles were refixed. To ensure the existing cantilever granite staircases were adequate for the building's new function, their load capacity was verified using in-situ proof load tests.

10: The Central Magistracy Building canopy was replaced with a replica canopy, as the original had deteriorated significantly

11: Arup's fire strategy involved fast response sprinklers, meaning barriers did not have to be inserted into E Hall's corridor

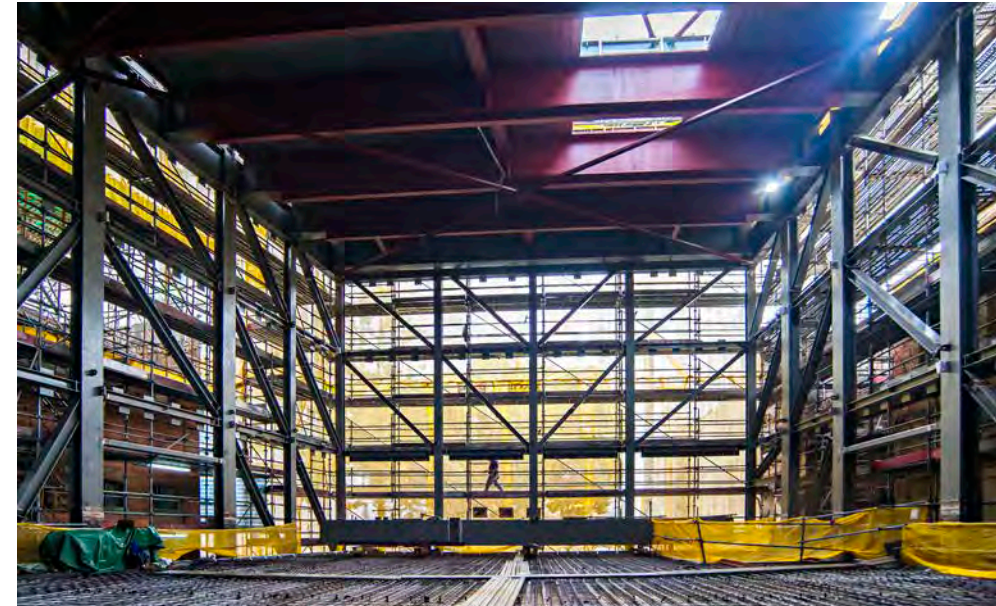

12.

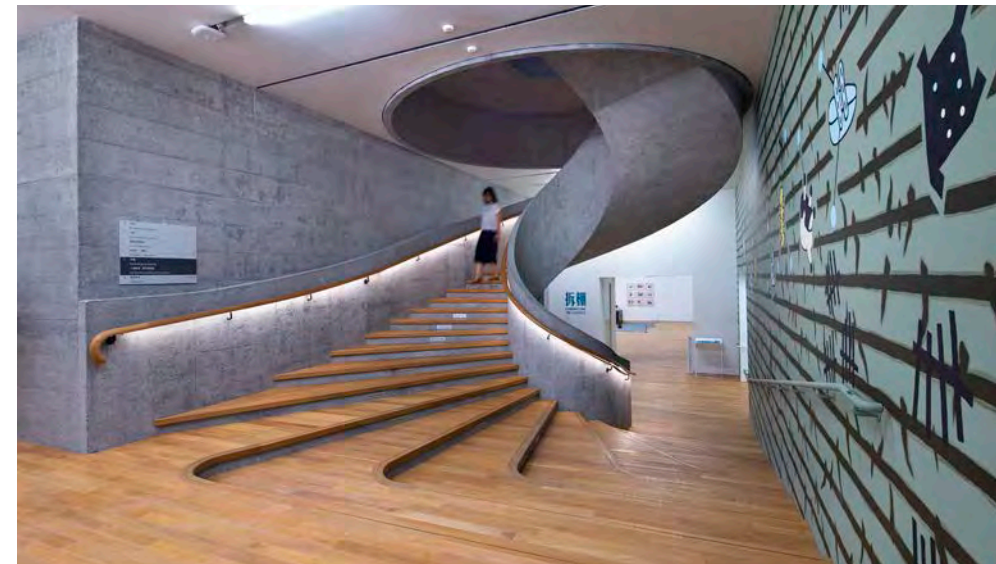

13.

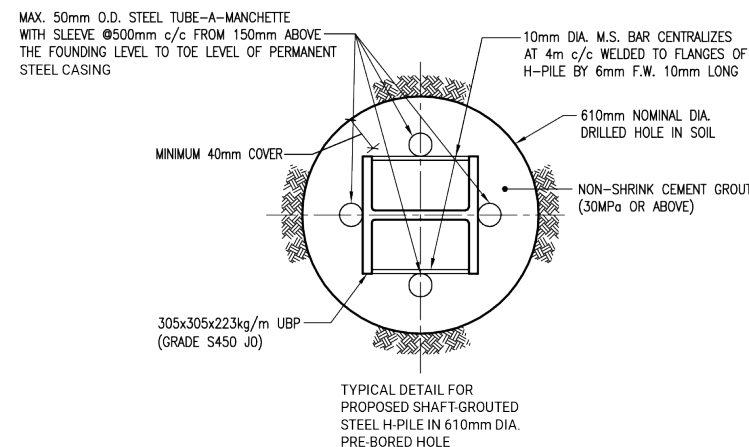

14.

12: Arup designed JC Cube's steel frame so the building would have a large column-free internal space

13: JC Contemporary's reinforced concrete staircase connects its two galleries

14: Innovative foundation solutions were needed for the two new buildings so as not to disturb the adjacent heritage structures

Fire strategy

As some features and character-defining elements of the buildings were constructed over a century ago and could not fully comply with the prescriptive requirements of modern fire safety codes, a site-wide fire engineering approach was adopted to formulate alternative safe designs. Using this strategy, Arup's Fire Engineering team was able to successfully preserve the unique heritage features of the buildings without compromising the safety of the structures or of their occupants.

In the Police Headquarters and the Central Magistracy, it was not feasible to modify the existing escape staircases to fulfil the prescriptive requirements for staircase construction and minimum exit widths. Arup proposed a number of solutions using a combination of specific fire protection systems. Evacuation analysis was conducted to compare the evacuation time under a code-compliant design and the proposed design. This demonstrated that people are able to leave the building more quickly under the new design arrangement because of early warning from the fire detection systems and the detailed fire safety management plan put in place. This design enabled openness and minimised the need for additional fire-rated doors along the building's spine corridor, allowing it to keep its original appearance.

In the former prison's B and E Halls, connections between floors were provided by internal circulation staircases. Prescriptive code requirements would have resulted in fixed barriers of at least 450mm depth suspended from the underside of the ceiling around the stair voids. However, due to conservation considerations, neither fixed smoke barriers nor automatic smoke curtains were desirable. To overcome this constraint, fast-response sprinkler heads were used, with computational fluid dynamics modelling determining their required activation time.

JC Contemporary and JC Cube

Herzog & de Meuron architects created two new buildings for the site, JC Contemporary and JC Cube, which provide space for exhibitions and the performing arts. The new blocks have reinforced concrete basements and a steel structure that rises above the historical boundary walls to create galleries within the buildings. The overhang results in new gathering spaces below, including a covered outdoor performance space under JC Cube where the laundry steps now provide sheltered tiered seating for visitors.



10.

Arup designed the column-free galleries within the buildings using a system of perimeter steel trusses which cantilever from a central reinforced concrete core. Two separate ‘boxes’ house gallery floors that are up to 7m high. The lightweight structural steel frame enables the galleries to cantilever out, minimising the requirement for new foundations adjacent to the heritage buildings, and the internal column-free space provides maximum flexibility for the various exhibitions housed in the buildings.

The concrete spiral staircase in JC Contemporary is an eye-catching visual element, drawing visitors up from the entrance and connecting the galleries inside the building. The stair structure was analysed using GSA static and dynamic models and constructed using traditional timber formwork. A BIM model was used to obtain the accurate setting-out dimensions during construction, with a 3D-printed model used for the coordination of the construction joints. A mock-up was constructed on site to agree the special concrete finish. After the formwork was removed, a needle gun finish was applied to the concrete surface; this matches the texture of the granite in the existing revetment site perimeter walls.

Innovative foundation solutions
With the bedrock beneath the site reaching a depth in excess of 80m, there were significant challenges when designing the new buildings’ foundations. The use of



15.

traditional percussive piles – which could cause excessive vibration or disturbance – would have heightened the risk of damage to the adjacent heritage buildings, which are founded on shallow footings. In addition, the site’s tight spatial constraints prohibited the adoption of the large-size foundation piles that are widely used in Hong Kong.

Arup adopted a two-pronged foundation solution for the two new buildings. The team used 610mm-diameter high-capacity shaft grouted friction H-piles in pre-bored holes for the foundations, and underpinned two buildings (F Hall and Ablutions Block) adjacent to JC Contemporary by using shaft grouted friction mini-piles to minimise the impact on these structures.

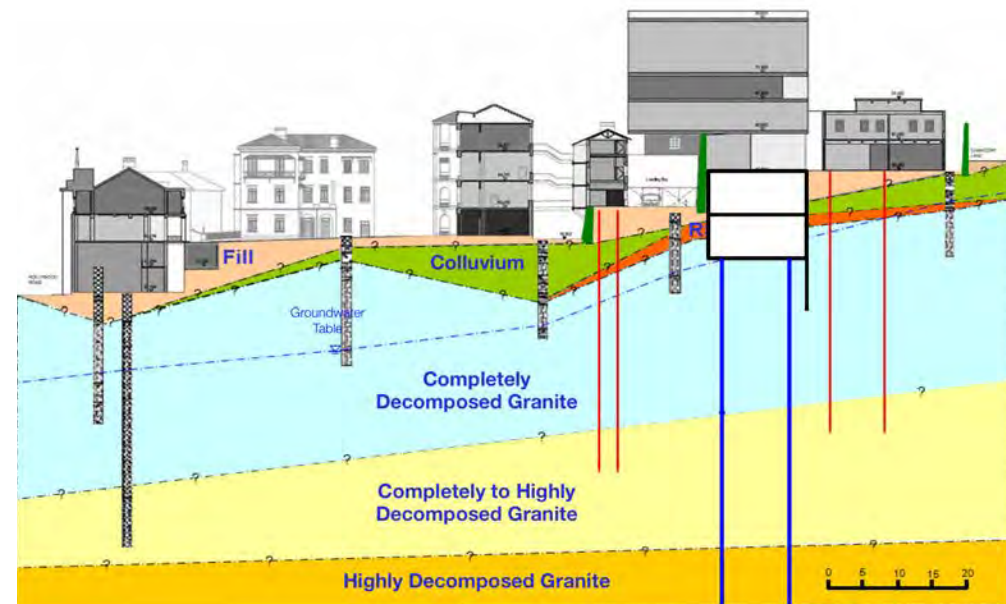

16.

15: To reduce the movement of adjacent buildings caused by the construction of JC Contemporary’s basement, the struts were pre-loaded

16: The new buildings were founded on 610mm-diameter shaft grouted friction H-piles in pre-bored holes (shown in blue)

A two-stage grouting process was implemented to enhance the ultimate skin friction of the pile shaft in the completely decomposed granite stratum. This piling method was proven to incur minimal vibration to the adjacent heritage buildings. Test piling was carried out on site to verify the design, with the piles tested to a peak load of 18,000kN – three times their maximum working capacity. This foundation system, with such high working capacity, was new in Hong Kong at the time, and Arup successfully sought approval from the Buildings Department for its use.

The 12m-deep excavation for the basement of JC Contemporary required careful design and a comprehensive monitoring system, as the work was carried out next to heritage buildings. Finite element analysis programme Plaxis was used to simulate the excavation process in order to predict the movements of the existing buildings and nearby heritage gravity-retaining walls ahead of construction. An 813mm-diameter contiguous bored pile wall was used with a grout curtain adjacent to F Hall, with four layers of steel struts supporting the basement excavation. Owing to the difference in ground level and surcharge load from F Hall, there were significant unbalanced forces that the construction process had to take into account. All the struts, except the topmost layer, were pre-loaded to alleviate the movement incurred on the adjacent buildings.

The pile wall functioned as both a temporary pile wall and the permanent wall. Lock-in stress in the pile wall throughout the temporary basement excavation stage was carried forward to the permanent design of

Awards

2018
Hong Kong Design Centre
Grand Award – DFA Design for Asia Awards

2019
The Association of Consulting Engineers of Hong Kong
ACEHK Annual Award

Hong Kong Green Building Council
Merit Award in the Green Building Award

The Hong Kong Institute of Architectural Conservationists
HKICON Conservation Awards – Revitalisation category

Hong Kong Institute of Architects
Special Architectural Award – Heritage & Adaptive Reuse
Award of Merit – Mixed Use Building

Hong Kong Institution of Engineers
Structural Division – Heritage Category
Grand Award
Fire Division – Fire Engineering
Grand Award

UNESCO Asia-Pacific Awards for Cultural Heritage Conservation
Award of Excellence



17.

the wall. A monitoring regime was established to track any movement, with a series of monitoring points placed on the buildings, retaining walls and roads surrounding the excavation site.

Bespoke façade
A bespoke cast aluminium brick façade wraps the new buildings, providing protection from the intense sun and heavy rains typical of Hong Kong’s subtropical climate. Arup’s Façade team worked for over two years on the research and design development, in collaboration with Herzog & de Meuron and façade contractor Permasteelisa. Each building is clad in over 4,000 cast

aluminium bricks made from 100% recycled alloy wheels – approximately 56,000 recycled alloy wheels were used in total. Arup provided advice on materiality, casting options, connection design and mock-up preparation.

There are four different variations of aluminium bricks, with apertures that range in size from the smallest, where the building is to be hidden, to the largest, which are placed in front of glazing. The complex geometry of these different bricks – with each style having a different pattern, undulation and thickness – was achieved by using six different die parts, and each brick was refined in order to enable an efficient cast-and-release mechanism. This method of production created a high-quality pure aluminium surface finish, which was necessary to receive the unique anodising treatment used to protect against corrosion.

The shape and dimensions of the aluminium bricks – each 1,200mm wide and 300mm deep – echo the size of the granite blocks of the existing revetment walls surrounding the site. Connections in between were carefully detailed to make them indiscernible to the public, while keeping them simple enough to make installation efficient. The bricks interlock to form the façade and are fixed to the structure every nine tiers of horizontal bricks. Wind posts are positioned every 3.8m. The system was tested for wind loading – including typhoon wind forces – and approved by the authorities.

Lighting Tai Kwun
The lighting design for Tai Kwun is intrinsically integrated with the architecture and finishes to help weave together the



18.

17: The new buildings are clad in bespoke cast aluminium brick façades

18: Each brick has been anodised to prevent corrosion

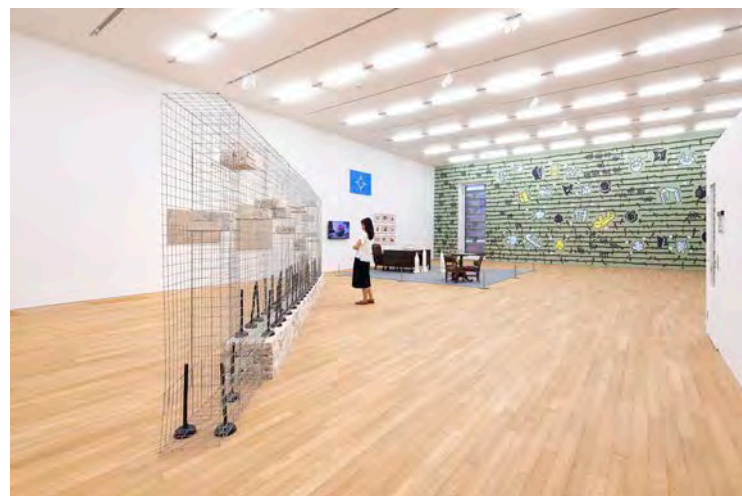

19: The gallery lighting levels are carefully controlled to protect the artwork
20: The laundry steps below JC Cube are a covered open space that can be used for performances

19.

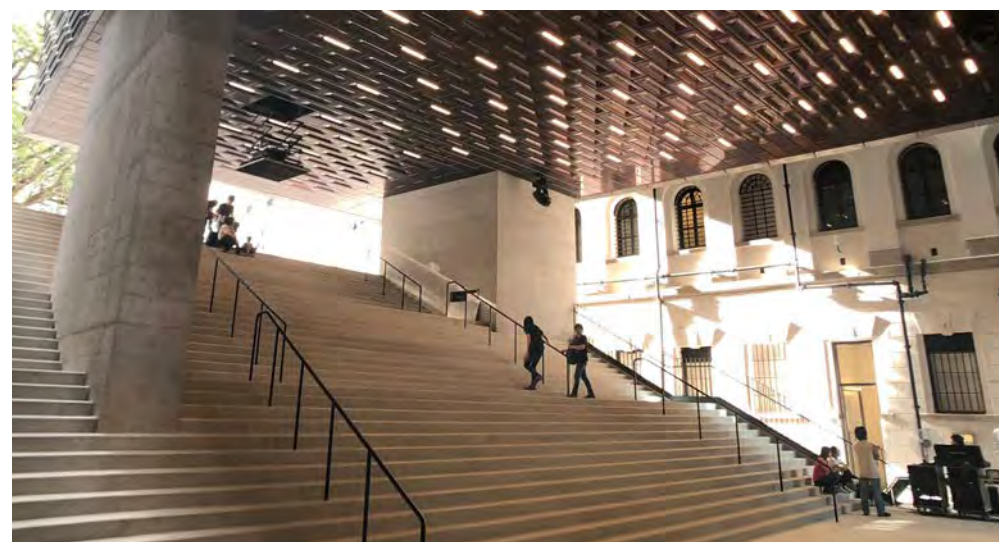

20.

various forms and spaces. For the two new buildings, Arup's lighting designers made full use of the aluminium bricks to express the texture of the façade while providing light. On the roof of JC Contemporary, the aluminium façade takes on a further functional form, acting as a solar shading grid designed specifically for the site to protect the top-floor gallery from direct sunlight. Arup carried out daylighting studies for the gallery.

Inside the gallery space, the ceiling is characterised by a stretched diffuse membrane which filters the incoming daylight and creates a diffused ambient light for the exhibitions, keeping daylight levels within a controlled range and addressing art conservation requirements. At night, electric lighting above the membrane takes over, maintaining the ceiling glow in place of daylight.

JC Cube houses an 8m-high multipurpose auditorium space, over which there is an accessible technical grid. Consistent with the overall theme of integrating the lighting and filtering light through the architectural fabric, the house lighting for this space is located above the grid, shining through to give a soft, general light to the space below. The glowing 'halos' of light that this creates on the grid are then referenced by spherical cast-glass LED pendant lighting in the adjacent auditorium lobby, visually connecting these spaces.

The lighting scheme for the outdoor public routes and spaces was designed to have minimal impact on the surrounding heritage façades while lifting the light level in these areas at night. It uses simple, low-impact, façade-mounted floodlights to light the paths and give a warm lighting effect in the two main outdoor spaces – the old prison yard

and the parade ground. Arup carried out research on the lighting design for similar types of historical buildings and, with conservation architect Purcell, developed the custom-made luminaires for the project. These enabled the lighting to be consistent with the architectural language of the heritage buildings.

In addition to using LED lighting, energy consumption is minimised during operation by using automated lighting control. Time clocks, light sensors and dimmable functions that cater for different uses have been incorporated into the lighting design. This was one of the sustainability credentials that helped the project achieve a BEAM Plus Gold rating.

New access and new public space

Buildings and spaces within this once disconnected compound are now connected by elegant staircases, link bridges and discreet structural openings through the historic buildings, with these openings created using concrete-encased steel portal frames. Link bridges cantilever from the perimeter truss structures in the new buildings, providing direct access to the adjacent prison cells in D Hall and E Hall, which were repurposed as dressing rooms for the mixed-use performance venue in JC Cube.

New public entrances have been introduced around the site, making the previously enclosed compound more publicly accessible. A circulation path was designed to connect the new public space created in the old parade ground with the prison yard. A concrete footbridge cantilevers 9m over the busy adjacent Hollywood Road and forms a vital connection to the site leading up from the escalators that link the Central and Mid-Levels districts in Hong Kong. These interventions mean that Tai Kwun is a ten-minute walk from the nearest Mass Transit Railway station.

Working on the project for over a decade, Arup has helped to transform and revitalise the colonial-era compound into a vibrant cultural hub, preserving its invaluable heritage for public enjoyment and for future generations to treasure. It is a shining example of heritage conservation work and has set a benchmark for future revitalisation works in Hong Kong. Since opening in 2018, Tai Kwun has been enthusiastically welcomed by the public – attracting more than 3.6 million visitors in its first year.

21: A concrete footbridge cantilevers over the adjacent Hollywood Road, providing direct pedestrian access to the compound

22: Tai Kwun opened to the public in 2018 and had over 3.6 million visitors in the first 12 months

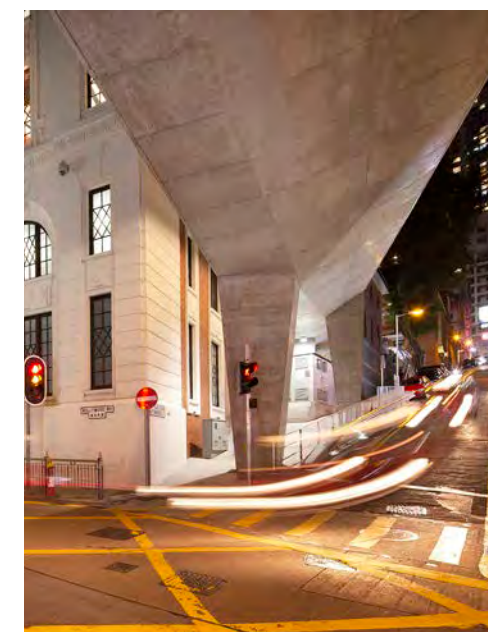

21.



22.

Authors

Florence Lam led the lighting design. She is an Arup Fellow, global lighting design leader for Arup and a Director in the London office.

Andrew Lawrence led the conservation elements on the project. He is an Associate Director in Arup's Specialist Technology and Research team and is based in the London office.

James Sze was the geotechnical discipline leader on the project. He is a Director in the Hong Kong office.

Paul Tsang was the Project Director. He is a Director in the Hong Kong office.

Young Wong led the fire engineering design. He is Arup's East Asia Fire Engineering team leader and a Director in the Hong Kong office.

Gabriel Yam was the Project Manager. He is an Associate in the Hong Kong office.

Nina Yiu led the façade design. She is a Director in the Hong Kong office.

Project credits

Client Hong Kong Jockey Club CPS Limited

Design architect Herzog & de Meuron

Conservation architect Purcell

Executive architect Rocco Design Architects

Building services J Roger Preston

Management contractor Gammon

Construction Limited

Civil, façade, fire, geotechnical and structural engineering, lighting, materials, security and safety consultancy services Arup:

Murray Allan, Pino Cao, Roy Chan, Che-Cheong Chan, Chris Chan, Henry Chan, Jonathan Chan, March Chan, Power Chan, Philip Chan, Sam Chan, Tiffany Chan, Chi-Kin Cheung, Crystal Cheung, Eric Cheung, Esther Cheng, Bobo Chow, Al Curry, Sunny Fok, Gordon Fung, Richard Hill, Richard Ho, Timothy Hoggins, Jason Huang, Dave Hui, Van Hung Tran, Anny Ip, Gabriel Kan, Daren Ko, Doris Kong, Kin-Kei Kwan, Thomas Kwok, King-Chak Lai, Alvin Lam, Francis Lam, Jerry Lam, Raymond Lam, Tom Lam, Andy Lau, David Lau, Fai Law, Justin Lau, Wai-Lun Lau, Andrew Lawrence, Katherine Lee, Brian Leung, Cherry Leung, Daniel Leung, Ming Lip, Andy Liu, Leona Liu, Lucia Liu, Rui-Bin Liu, Victor Liu, William

Loasby, Benjamin Luk, Hazel Luk, Louis Mak, Melissa Mak, Wendy Mak, Gavin Maloney, Andus Mok, Berny Ng, Yiu-Wing Ng, Jeffrey Ngai, Jason Paget, Jeff Po, Andrew Sedgwick, Ezra Setiasabda, Elvis Sham, Jeff Shaw, Leo Shu, Ken Siu, Yuanyuan Song, Andrew Sun, Frankie Sze, James Sze, Nelson Tang, Sarah Tattersall, Ka-Lun To, Vira Tong, Santiago Torres, Anatasia Tsak, Kelvin Tsang, Paul Tsang, Victor Wan, Youngky Wanady, Anson Wong, Eric Wong, Evan Wong, Sally Wong, Stewart Wong, Wai-Hong Wong, Young Wong Lucy Wu, Gabriel Yam, Matthew Yam, Jacky Yau, Jess Yip, Rex Yu, Ricky Yu, Nathan Zeng, Lyn Zuo.

Image credits

1, 4–16, 18–21: Arup

2, 3: Tai Kwun

17: Heliservices (HK) Ltd

22: Herzog & de Meuron/Iwan Baan

Adaptive learning

This new university building houses laboratories and performing arts areas, with future flexibility built into every aspect

Authors Rob Fleury, Ben Moore, Andrew Pettifer and Stefan Sadokierski

The Science and Engineering Building (SEB) at UNSW Sydney is the latest addition to the elite physical sciences precinct at the university's Kensington campus. Opened in 2019, the new ten-storey SEB offers ultra-modern research facilities, science laboratories, classrooms and multipurpose performance spaces.

The SEB features large internal atria and highly connected spaces, designed to encourage users to come together to collaborate and innovate. The building has a flexible laboratory core, with modules arranged around a central service corridor. The facility incorporates 25,000m² of research space and is highly adaptable; the laboratory spaces can be reconfigured with minimal disruption.

A critical project requirement was that this flexibility of space had to be balanced

against ensuring the building was energy efficient. Arup worked closely with UNSW and the wider design team to deliver a solution that fulfilled both these requirements: the laboratory spaces can be modified, and the building design is sustainable and also integrates with pre-existing campus-wide systems. This strategy for adaptability supports the university's ongoing research and teaching programme, and helps future-proof the campus. Flexible solutions were also found for the design of the theatre and performance area located in the basement of the building.

In collaboration with architects Grimshaw and contractor Multiplex, Arup provided multidisciplinary engineering services from the feasibility phase through to construction. Post-build, the firm designed the migration of laboratories and studios from existing campus buildings to the SEB. Arup's services included audio-visual and

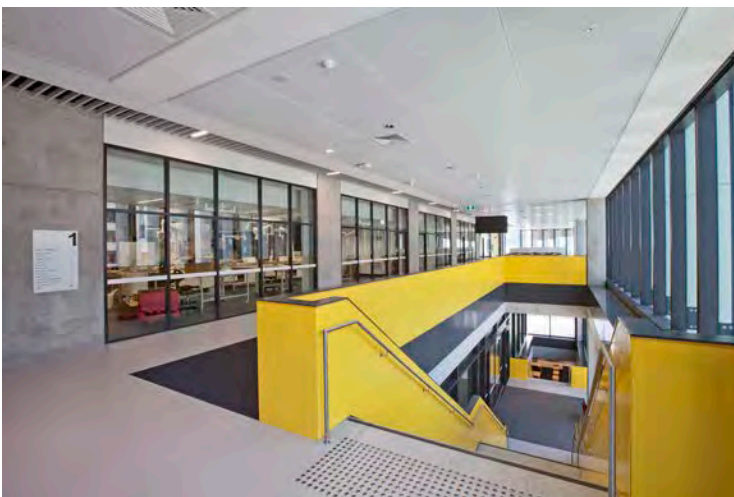

1: The highly interconnected spaces in the SEB are designed to promote collaboration
2: The new ten-storey facility features laboratory spaces, classrooms and performance areas

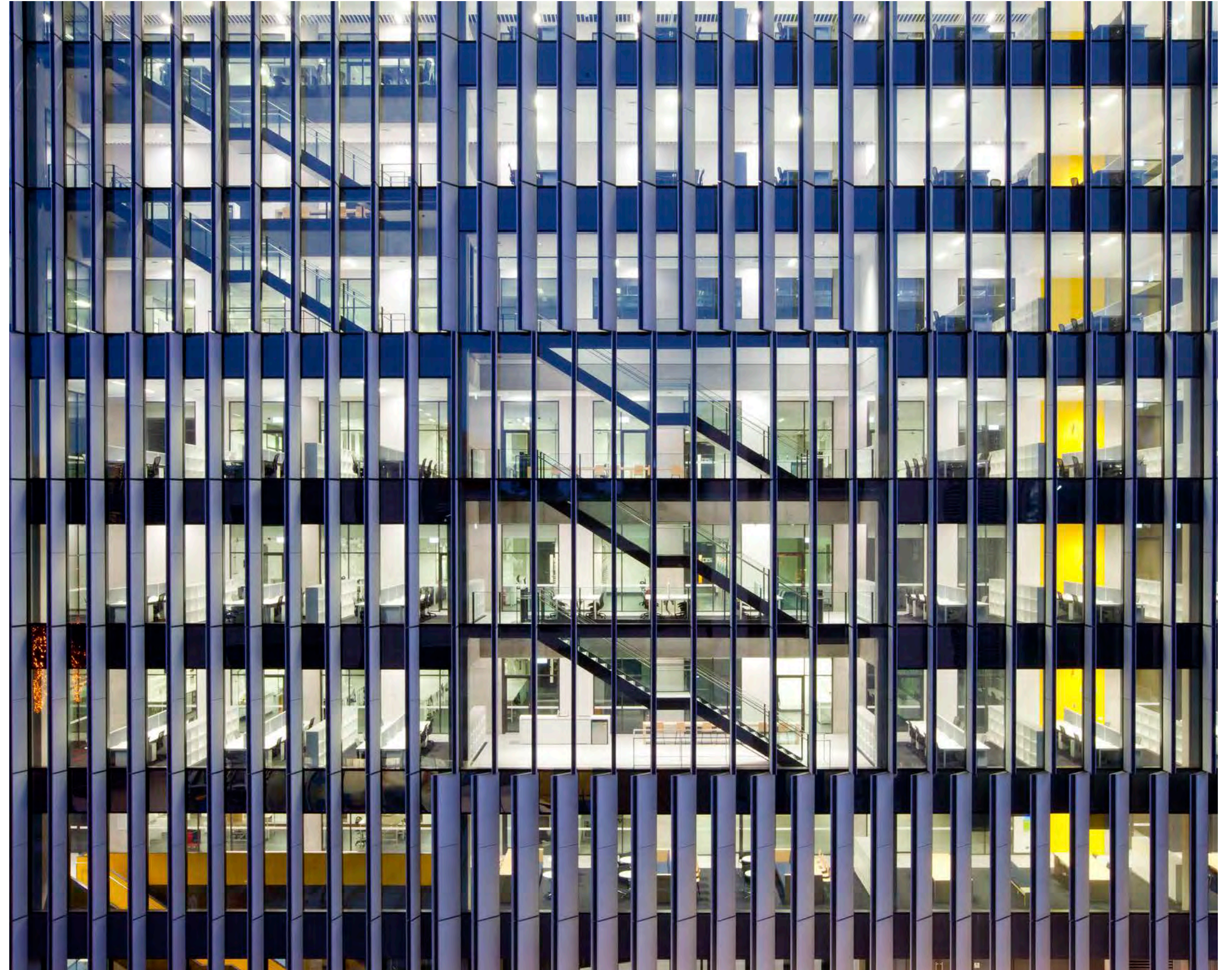

multimedia, electrical, fire and mechanical engineering, laboratory gas and sustainable buildings design, theatre consulting, and vertical transportation.

Genesis of project and site preparation

Arup has worked with UNSW for over 40 years on projects on their Randwick campus. Its most recent work for the university on the Kensington campus was the Hilmer Building for Materials Science and Engineering, where the firm provided a peer review of the building services design. This was in addition to independent commissioning work that included elements of laboratory fit-out. Following on from the

successful completion of this work, Arup was commissioned at feasibility stage for the design of the SEB (the completed SEB is linked to the Hilmer Building by bridges at each floor level) to develop design options for the ventilation of the laboratory spaces. The firm was then asked by Multiplex to provide design development of the mechanical, electrical and laboratory gas systems, before being retained in a review role during the design and construction element of the project. The addition of the SEB and Hilmer Buildings was part of UNSW's 2025 strategy, which aims to position the university as a world leader in research.

Arup developed an early works package for the initial stage of the project. This saw the demolition of several buildings on the site where it was planned the SEB would be constructed, including the removal of an electrical substation that served several buildings in the lower campus precinct. The firm designed a temporary substation to continue to supply the surrounding buildings while the demolition took place, and then designed the new permanent substation located in the basement of the SEB. This work required multiple diversions of services and a detailed strategy for minimising electricity supply shut-downs to existing buildings in the campus during the transfer.

Stakeholders

The new facility brings the Schools of Chemical Engineering, Chemistry, and Arts and Media together under one roof (they had previously been housed in separate buildings). This combination means that the SEB has a diverse set of requirements, with high-level scientific research taking place on some floors and theatre and performance spaces located on others. For the wide range of scientific research carried out in the facility, there is a mixture of wet and dry laboratories, laser laboratories, microscopy suites, nuclear magnetic resonance and pilot halls. All these applications require intensive servicing to maintain various laboratory conditions – such as temperature control, air quality and vibration criteria – and support high-specification laboratory equipment. Some laboratories also require cascading pressurised containment. Located in the basement, the Creative Practice Lab, Io Myers Studio and Studio One have their own set of needs. These spaces are designed to host performances, video screenings, film shoots, cross-media installation works and rehearsals.

The UNSW estate management team and the building's end users provided input on the high-level laboratory design and the performance spaces at an early stage of the project. Arup worked with UNSW, the architect and laboratory planner HDR to carry out three sets of user group workshops to detail the specific requirements for each laboratory, looking all the time to incorporate adaptability into the design. Solutions had to be cost-effective, and it was particularly critical that the new facilities could integrate with existing campus-wide systems, including the building management system that controls and monitors the mechanical and electrical systems.



5.

5: Arup's SoundLab technology was used to demonstrate to the client the active architecture system it proposed for the performance spaces

6: The SEB uses plant located in adjoining buildings

common manifold exhaust reduced operational costs, saved considerably on space (due to reduced riser requirements) and allowed for greater adaptability within the laboratories. This was the first time manifold fume cupboards had been installed at UNSW.

Arup carried out a risk assessment on all the chemicals that could enter the manifold system. This determined that some dedicated fume cupboards – 16 in total – were required to deal with chemicals that needed individually ducted exhausts, such as hydrofluoric and perchloric acid fumes (due to their hazardous corrosive nature), as well as for the instances where there was a cross-contamination risk between chemicals.

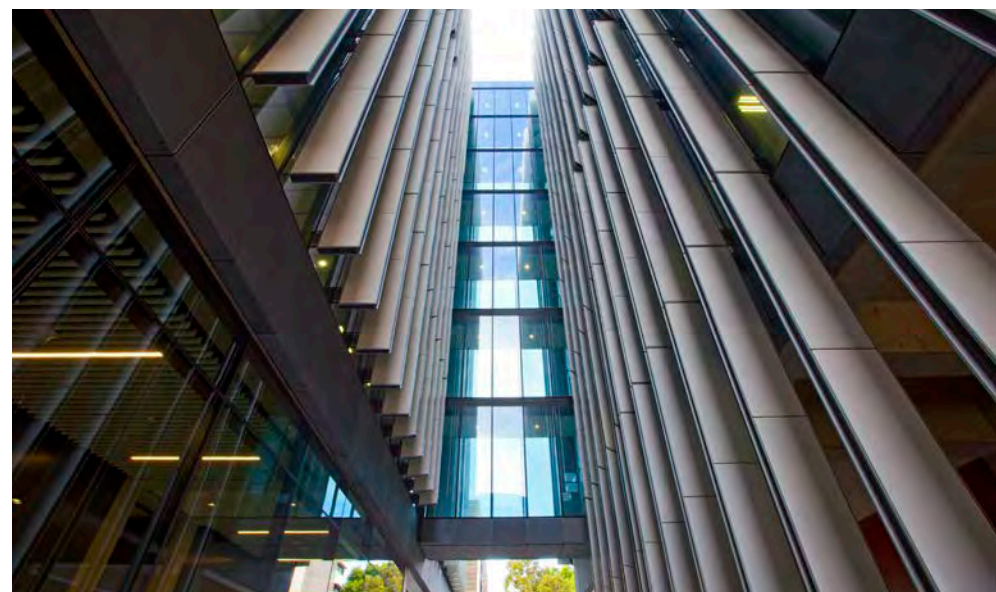

3.

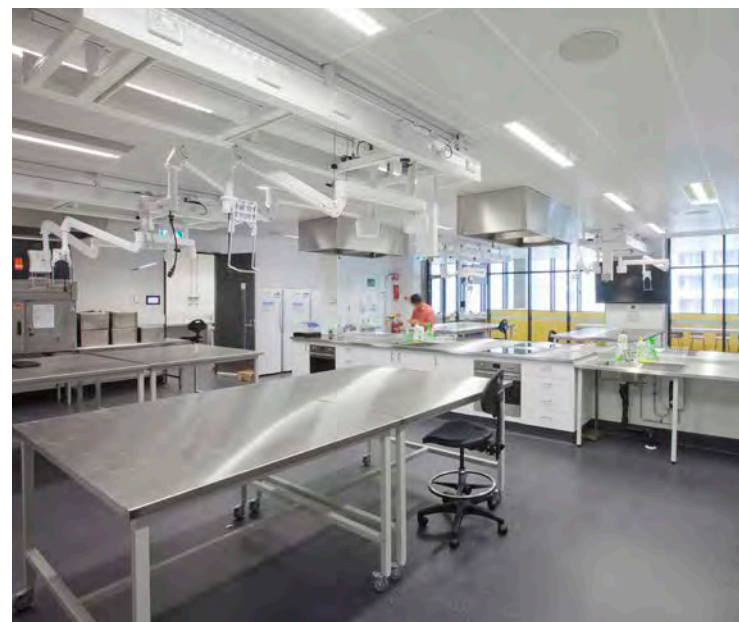

4.

3: The SEB and Hilmer Building are connected by bridges at every floor

4: Three user group workshops were held to get input on the design of the laboratory spaces

Arup's design adapted the standard audio-visual systems to respond to the needs of the new space typologies in the SEB, and further enhanced them. The facility focuses on collaboration and self-led research, and the new interactive audio-visual systems were set up to facilitate this type of work across the lecture theatres, laboratories and classroom spaces. Arup's Theatre Consulting team also worked with the School of Arts and Media to develop the specification for their performance spaces. This included demonstrating to the client the different ways performances in the space could sound using the proposed active architecture system. This uses a complex arrangement of microphones and speakers to recreate different aural environments and was demonstrated using Arup's SoundLab and by visiting similar venues previously designed by the firm.

Sustainability credentials

Arup engineered the building's layout, central plant and equipment to contribute to the SEB's energy-efficient operating systems. High-performing window glazing, good levels of thermal insulation and the use of bore water for non-potable water supply were some of the sustainability initiatives included in the design. The existing non-potable water system on campus was expanded, with a plant room for the extended system included in the new building. In addition, Arup was able to gain precinct-wide efficiencies through the installation of a combined chilled-water plant for the SEB and the adjacent Roundhouse Building. The contrasting building needs – with peak loads typically in the evening in the Roundhouse entertainment venue and in the morning and afternoon in the SEB – were taken into account when developing the system. The compressed air plant in the adjoining Hilmer

Building has been used for the SEB, saving plant space, capital costs and the need for extra ongoing maintenance.

With its high density of fume cupboards and significant exhaust air requirements, the SEB is a mechanically intensive building. Arup used the International Institute for Sustainable Laboratories' Labs21 Tool Kit to benchmark the energy performance of the building and equipment such as chillers, boilers, pumps and fans. In the laboratories, the air flow control incorporates room temperature feedback, which means air flow can be kept to a minimum, as the system constantly assesses the climate.

Laboratory design and flexibility

The SEB has seven levels of laboratory space, with over 7,000m² of wet chemistry laboratories and 10,000m² of office, breakout and non-laboratory teaching space. The Mark Wainwright Analytical Centre, for example, houses major instrumentation and advanced scientific tools for electron microscopy and is a leading research facility in its field. On each level, the laboratories are positioned adjacent to the service corridor, with write-up space and offices placed on the building perimeter. The service corridor provides the flexibility to direct services – such as central gas, nitrogen and argon – into any of the laboratory modules.

The laboratory design needed to respond to the many different uses and allow for adaptability. Rather than only use fume cupboards individually ducted to a central supply system, the method typically in place elsewhere on campus, Arup designed a hybrid system, with a manifold used in conjunction with dedicated cupboards. Connecting multiple fume hoods to a

Supply and exhaust ducting to the laboratories was standardised across the lab areas. This allowed for maximum versatility in the fit-out of laboratory spaces and meant that ducting could be pre-fabricated off site. A number of the laboratories require physical containment with negative pressure relative to the access corridor, including some classified to the second level of containment (PC2). Part of the flexibility in the ventilation system and the servicing is that laboratory modules can be upgraded to physical containment rated facilities at a later date if required, with minimal additional work. Careful design was carried out around the laser laboratories, which require tight temperature and humidity control (to within ±1°C) and need specific access controls to ensure users' safety.

Arup worked closely with the laboratory planner to catalogue the user requirements for



6.

all the laboratories, including equipment and power and gas supply. This enabled a large database to be developed, which was integrated with the BIM model to facilitate coordination and to automatically generate room data sheets. All the design team worked in this 3D environment. The model was issued to Multiplex, which developed it further in order to produce the workshop drawings.

Multipurpose performance spaces

The construction of the SEB provided an opportunity to incorporate enhanced performance space for the School of Arts and Media – the site of the building was previously used for the Creative Practice Lab, the arts unit that supports teaching and practice-led research within the School. For UNSW, the aim was not only to recreate the previous facilities but to enhance them by bringing music together with drama, physical

performance, dance and acrobatics in one facility. Arup’s theatre and audio-visual consulting specialists designed improvements for the studios including the introduction of foyer screens, paging systems and upgraded amenities to ensure a seamless experience for patrons and stagehands.

For the Io Myers Studio, the firm designed an active architecture system that uses electro-acoustic enhancement to increase the ‘natural’ reverberation time of the studio space to support a wide range of uses – these include chamber and jazz music, amplified music, theatre and spoken word. The reverberation time in the space can be modified to make it seem as though the performer and audience are in a more complex acoustic space such as a large concert hall or an arena. Longer reverberation times are preferred for classical music

performances, with shorter reverberation times preferred for dramatic theatre performances to promote speech intelligibility. This system allows the creative possibilities of the space to expand significantly beyond a small black box theatre. Actors and musicians get the opportunity to hear what it sounds like to play or perform in a large hall – this is crucial to the development of musicians and performers.

Fire engineering

The combination of laboratories and theatre space in one building presented challenges for the fire engineering strategy. In the laboratories, the strategy was kept simple, with the smoke exhaust set up to use the mechanical systems already in place for fume exhaust from the research activities. This reduced costs and allowed flexibility to modify the laboratories in the future – something that would not be straightforward if a dedicated smoke exhaust system was used. As some of the research processes and equipment produce smoke and dust that would set off traditional smoke detectors, thermal detectors were installed,

along with manual fire call points and a sprinkler system.

The fire engineering strategy was to split the building into three horizontal two-hour fire compartmentation zones. This meant fire separation was not required between the laboratory and office space, enabling good visual connectivity between these areas. Similarly, the centrally located open circulation stair running through the building provides visual connectivity between levels. Some fixed fire-rated construction was included around the stair void, which enabled circulation but provided some fire separation. For the stair cores elsewhere in the building, a stair pressurisation system

was used. Arup’s Fire Engineering and Building Services team worked closely on the system, which distributes air vertically through the whole stair.

While the occupants of the laboratory areas typically are familiar with the space, the theatre requires a different fire strategy to reflect its use as a public venue, with users less likely to be accustomed to the layout. The venue hosts events that often occur out of typical office hours, when the rest of the SEB is relatively empty. The theatre space is operated independently from the laboratory areas of the building, from both a fire and security perspective. Arup’s fire engineered approach, using detailed smoke modelling,

facilitated the removal of the requirement for dedicated smoke exhaust in the theatre space. Like the laboratories, there are no smoke detectors in the theatre spaces. Special effect smoke is often used, so thermal detection, along with a sprinkler system, was installed.

World-class facilities

The UNSW 2025 strategy sets out the university’s commitment to carrying out world-leading research and improving educational quality by deploying innovative face-to-face and digital learning tools. The Science and Engineering Building fits well within this strategy, by offering world-class facilities to support ground-breaking research.



7.

7: Arup designed a hybrid system for fume cupboard exhaust, with a manifold used in conjunction with dedicated cupboards

8: Arup used the Labs21 Tool Kit to benchmark energy performance

9: A large database was integrated with the BIM model in order to generate room data sheets

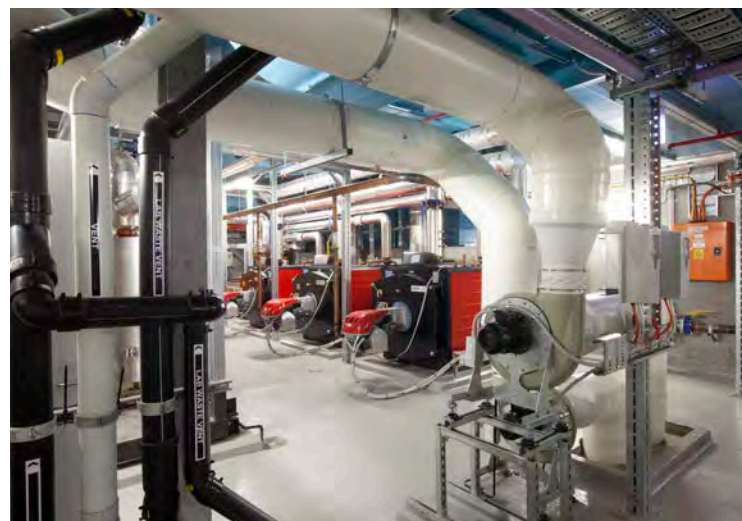

8.

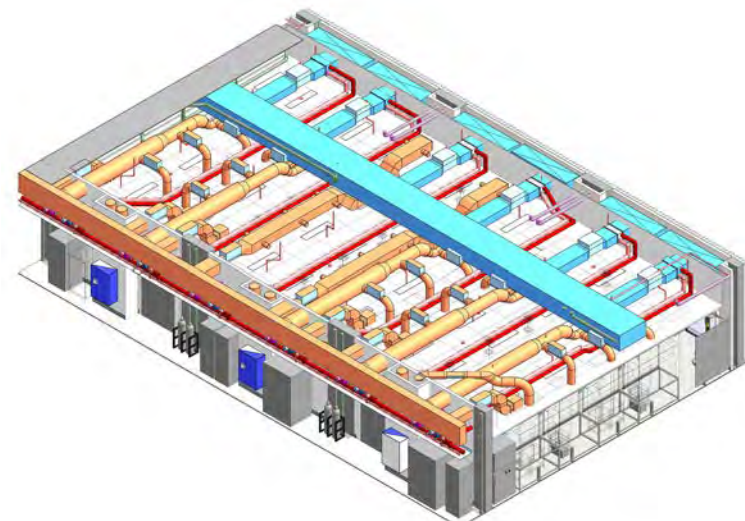

9.

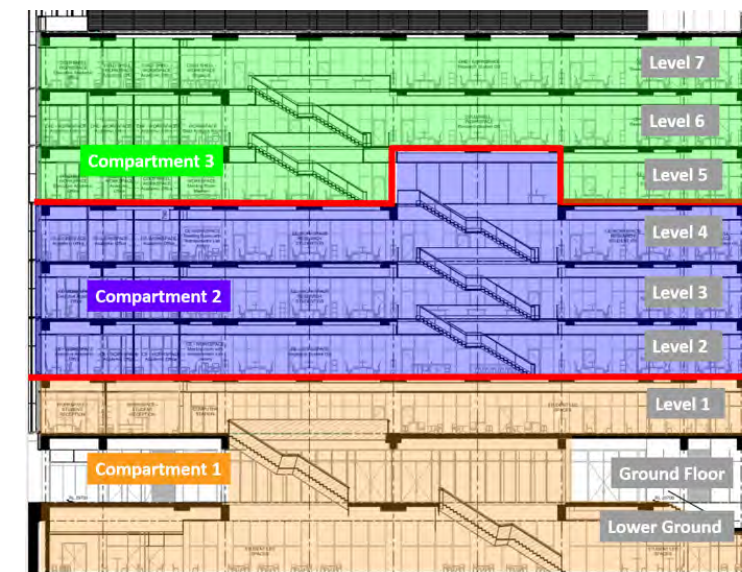

10.

10: The building was split into three horizontal two-hour fire zones in the fire engineering strategy

11: Opened in 2019, the SEB offers world-class research and performance facilities

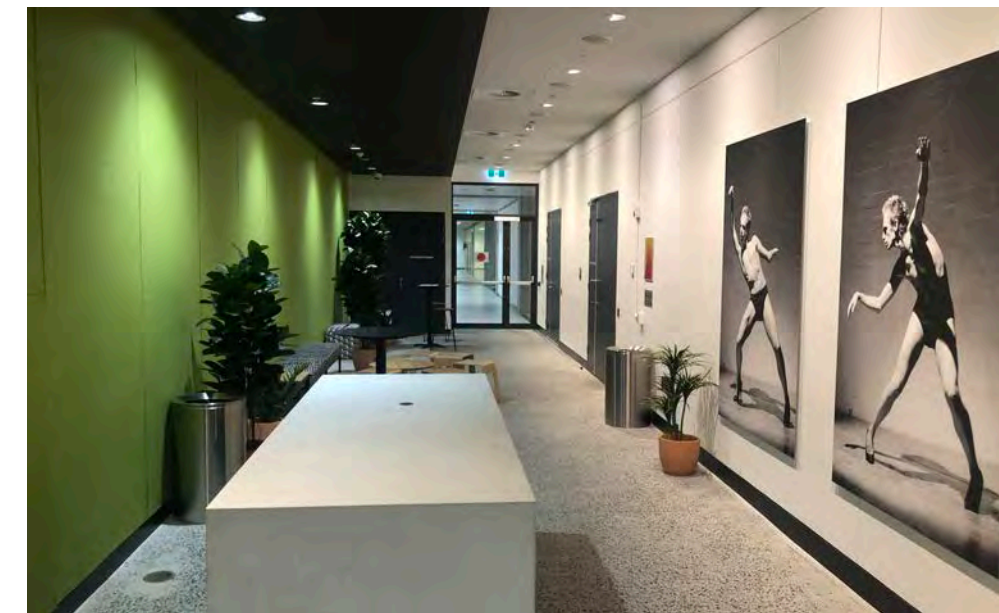

11.

Authors

Rob Fleury led the fire engineering design and is an Associate in the Sydney office.

Ben Moore led the audio-visual and theatre design elements of the project. He is an Associate in the Sydney office.

Andrew Pettifer was the Project Director and is a Principal in the Sydney office.

Stefan Sadokierski was the Project Manager and is Arup’s global skill leader for mechanical services. He is an Associate Principal based in the Sydney office.

Project credits

Client/Contractor Multiplex

End-user UNSW Sydney

Architect Grimshaw

Laboratory planner HDR

Civil and structural engineer

Taylor Thomson Whitting

Audio-visual and multimedia, electrical engineering, fire, mechanical, sustainable buildings design, theatre consulting, laboratory manifold risk consultancy and vertical transportation Arup:

Jakki Artus, Vince Bombardiere, Rory Brenan, Tom Brickhill, Nigel Cann, James Cho, Tate Dogan, Tim Elgood, Bernard Farrell, Rob Fleury, Reshmi Govindankutty, Scott Hampson, Mairead Hogan, Patrick Hoy, Kim Jones, Ciaran Lynch, Marc McDonald, Ben Moore, Andrew Pettifer, Simon Pimley, Stefan Sadokierski, Len Samperi, Helena Sjoberg, David Stidolph, James Trevorrow, Sihui Wang, Ryan Wilson, Thomas Yates.

Image credits

1–4, 7, 8: Multiplex

5, 6, 9–11: Arup



A precision-focused cancer treatment

Enabling sophisticated, high-energy technology to be used in a safe and sustainable environment

Authors Nick Ashby, Hywyn Jones and Dave Pitman

The Christie Proton Beam Therapy (PBT) Centre in Manchester is the UK's first National Health Service (NHS) multi-room, high-energy PBT facility. In PBT, a cyclotron (a type of particle accelerator) is used to create a beam of high-energy protons. This beam can then be focused with great precision on tumours, meaning that there is less damage to the surrounding tissue and vital organs while the tumour still receives a high dose of radiation. PBT is most suitable for certain kinds of cancer, such as complex brain, head and neck cancers and sarcomas. It is particularly useful for treating these types of cancers in children, for whom traditional radiotherapy carries an elevated risk of damaging the brain and impairing cognitive development and hearing.

The building design for this new facility was shaped by the technology used for PBT. The treatment requires an intensive energy supply for the cyclotron, which accelerates protons to two-thirds the speed of light, and a substantial concrete structure to house the equipment and protect patients, visitors and staff from the radiation generated.

Arup worked on the project from concept design stage through to completion, providing structural, building services, energy modelling, acoustics and vibration engineering, and geotechnics and sustainability services. Having previously designed PBT facilities in Krakow, Arup used that design experience by incorporating the team from Poland as reviewers at each design gateway.

Proton Beam Therapy facility
The 12,000m² treatment centre is part of a five-storey building constructed on a constrained urban site in a live hospital environment. Its construction required demolishing buildings and diverting and accommodating existing services. The PBT facility, which is also connected to an adjacent building, includes the cyclotron and four gantry rooms; three for treatment and one fitted out as a research room. It also houses clinical facilities that include CT and

1: PBT is particularly useful for complex cancers and for treating cancers in children, as the beam can be focused with great precision, causing less damage to the surrounding tissue



2.

2: The Christie PBT Centre was constructed in a highly constrained urban site

3: The facility includes the cyclotron and four gantry rooms

4: CT and MRI scanning are among the treatments available in the clinical facilities



3.

MRI scanning equipment, outpatient areas and administration accommodation.

The gantries, each 10m in diameter, are large, complex components that contain the treatment delivery system. They can rotate 360 degrees so the patient is not required to move position during treatment. Complex engineering solutions were required to house the gantries and the 150-tonne cyclotron, as they needed concrete radiation shielding walls – in places, these were up to 5m thick. Over 11km of conduits and a further 1km of pipework were precisely located and embedded in the walls. The overall electrical load for the building, including the equipment, is 2.8MVA, with a cooling load of 1.4MW – these loads (based on four fully



4.

operational gantries) are more than ten times those used in typical radiation therapy. A new major primary substation was designed adjacent to the facility to meet these demands.

PBT facilities are inherently energy-intensive; the amount of energy needed to operate the equipment and cool it is substantial, and there are strict equipment supplier servicing requirements that need to be met to ensure that everything runs safely and accurately. Providing this baseline high level of energy while still providing resilient, sustainable solutions was challenging. Arup's experience of designing sustainable buildings meant that the firm was able to minimise the impact of the operational energy requirements through innovative solutions.

The firm was appointed as the Accredited Person and Assessor for BREEAM. Due to the specific nature of the scheme, Arup worked closely with the Building Research Establishment (BRE) to define bespoke credits and assessment methodologies for some elements. The firm's building physics specialists advised and agreed key principles with the BRE. The power used by the particle accelerator and beam line magnets to generate the high-energy beam results in substantial levels of waste heat. Two large heat pumps take this waste heat and use it to provide heat for the ventilation system for the clinical side of the building. This solution led to reduced operational costs and carbon emissions, and resulted in the facility receiving a BREEAM 'Excellent' environmental rating. Arup also designed the deionising system for the cooling water to meet the more stringent water quality requirements for the PBT. This process

maintains the required conductivity and pH levels for the water.

Procurement

Arup worked side by side with The Christie to explore different solutions to the site's spatial limitations and inform early design concepts as part of the procurement process for the specialist PBT equipment. Three proton therapy equipment (PTE) vendors engaged in a competitive dialogue during the project initiation design process. Each had a different set of requirements, all of which would have a significant effect on the size and shape of the structure that would house the accelerator and gantries, the associated builders' work and the plant room strategy. To inform the correct procurement decision, these variations in the build cost were addressed as part of vendor selection – this was a crucial issue given the significant equipment costs, which were a



5.

5: The busy site had a public highway nearby, as well as being adjacent to pre-existing hospital buildings and residential properties

6: An integrated BIM model was used to plan the many complex aspects of the facility

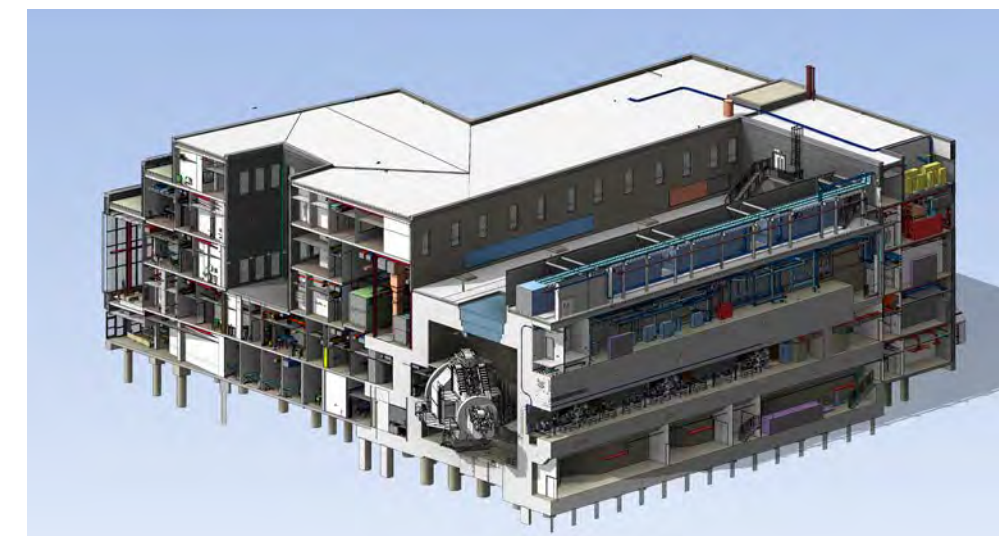

6.

substantial portion of the overall construction cost of the facility.

Arup developed three different designs at concept stage based on each vendor's requirements and then progressed two of these through further phases of design and procurement. With large variations between the equipment layouts, Arup developed a strategy that created a tolerance zone along the interface between the shielded areas and clinical spaces. This innovative approach kept the programme on track. The final design was carried out with the PTE provider Varian Medical Systems, which worked closely with Arup and contractor Interserve to improve buildability and refine the design requirements.

Site constraints

Given the site's shallow bedrock and high water table, the large three-storey concrete structure of the treatment block was planned in a way that would minimise construction below ground. Planning, phasing of works and logistics were important considerations, with the facility located in a confined urban site adjacent to existing healthcare facilities and nearby residential properties. In addition, a link corridor with neighbouring clinical buildings was required to create a seamless facility for patient experience and access to the wider Christie site.

Complex existing surface and foul drainage crossed the site and needed to be diverted, yet kept live during construction.

Arup's Civil Engineering team assessed this infrastructure and designed safe solutions to integrate it with the new building's requirements, allowing phased transfer of foul flows in the network. Two culverted watercourses crossed the site and it was not possible to divert them entirely, so one was retained below the footprint of the new building. To minimise maintenance, a robust and hydraulically improved in-situ concrete culvert was developed; this reduced the risk of any blockage and was designed to allow for robotic access for clearance and inspection.

The site was also constrained by a public highway to the south and the occupied

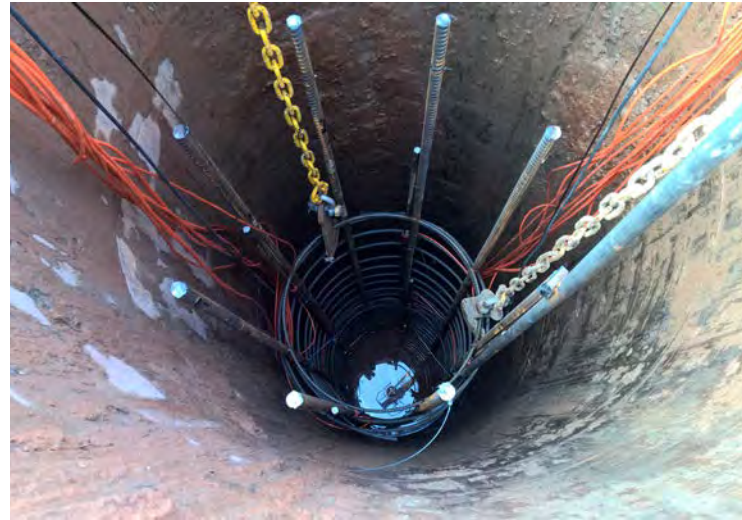

7: The piles were designed to ensure the structure met the settlement criterion, which was more than five times stricter than for a typical building

8: Arup demonstrated that its solution met the vibration criteria by constructing a full-scale test pile and loading it to 150% capacity while monitoring settlement

7.

hospital buildings to the north and east. Access to site and materials storage during construction were critical issues. The strategy included a holding area for vehicles and ‘just in time’ lean delivery processes for the site.

Vibration and movement

To ensure business continuity for the adjacent live hospital facilities, Arup’s

vibration specialists carried out an early vibration assessment and developed mitigation advice for the demolition and construction phases. This included an appraisal of the site impacts on the nearby operational outpatient treatment centre. The team also assessed the equipment within the new facility, which had to achieve vibration criterion A (VC-A), and incorporated in the final design additional equipment-isolating elements where required.

Arup’s Geotechnical Engineering team reviewed the existing ground investigation information and specified a two-stage geotechnical investigation process. This allowed ground risks to be assessed prior to demolition on site, particularly in relation to the tight beam line magnet movement tolerances. The settlement criterion of less than 2mm over 10m per year is more than five times more onerous than for a typical building, and this strict criterion was outside the normal limits that piling contractors work to. By taking on both the detailed pile design and site supervision responsibility for this element of the works, Arup was able to resolve this issue. The firm created a solution that met the stringent movement criteria and was justified through detailed monitoring of a full-scale test pile that was loaded to 150% capacity. The foundations for the facility were formed with piles rotary bored into the bedrock 15m below ground level.

The High Speed 2 (HS2) rail route is proposed to pass the site – during the building design phase, the route was within 40m of the facility. The tunnel for HS2 is likely to be formed by a tunnel boring machine; the construction could cause ground movements outside the stringent

limits of the PBT equipment and could also generate vibrations within the rock. By identifying this risk early and carrying out an assessment, Arup provided The Christie with the tools to liaise with HS2 in future and mitigate these potential issues.

Construction and phasing

Due to the logistical challenges posed by the unconventionally thick sections of the concrete structure required for shielding, the build sequence required constructing the PBT equipment spaces first. The clinical element of the building followed, with the installation of the PBT equipment overlapping with this adjacent construction phase. The interface between the clinical building and the shielded areas containing the cyclotron and gantries was critical for the programme. Some of the air handling units (AHUs) needed to be installed and working before the PTE vendor began their installation. The AHU plant room sits partially on top of the shielded area and the structure for this could not be completed and made weatherproof until after the completion of the concrete lid above the gantries. To keep the project on programme, Arup designed an alternative framing arrangement, in which a small temporary plant room was created within the first phase of steelwork erection. This enabled the AHUs to be installed prior to the completion of the gantry area.

The building’s height was a critical planning constraint due to the nearby residential properties, and this was capped as part of the site’s masterplan. Arup carried out a detailed structural options appraisal to inform the choice of material and the structural solution used to minimise storey heights to ensure the building was the specified height, and to limit planning risks. To create the required floor-to-ceiling heights within these constraints, while also meeting the strict programme, the firm designed an unconventional steel-concrete hybrid framing solution that minimised the structural depth of the floor slabs, thus ensuring the internal height requirements were met.

Radiation shielding

It was essential that the shielding elements of the building ensured staff and visitors would not be exposed to unsafe levels of radiation. The high-energy neutrons emitted by the equipment are powerful enough to activate some surrounding materials, with certain chemical elements more susceptible to activation than others; therefore, getting

the concrete mix design right was crucial. Arup worked with radiation protection adviser Aurora to review the chemical content of the concrete mix design to ensure it did not contain any potentially reactive chemical components. Concrete contractor Heyrod Construction and concrete supplier Hanson were involved at an early stage, contributing to the design process. The mix design incorporated a low water content, limestone aggregate to minimise thermal movements and 70% cement replacement using ground granulated blast furnace slag to minimise heat gains during curing.

Specific material tests were carried out regarding the heat of hydration gain to minimise thermal movements, culminating in a full-scale pre-construction test pour of a typical 5m x 3m x 3m wall section. All the main elements were included in this test pour: embedded conduits and pipework, thermocouples to measure the concrete temperature and a ‘joggle joint’ detail. This zig-zag joint profile was required in the finished building to ensure each concrete shielding pour locked securely together. By profiling the joint between the concrete pours, it ensured that there was no direct route for neutrons to pass through, thus preventing any radiation leakage.

Concrete density was also a critical parameter of the shielding design – Arup specified target and minimum mix densities and had the concrete mix tested prior to construction starting on site. This enabled the final oven dry concrete density to be calibrated against the fresh wet density value, which was tested on site prior to and during each pour to help ensure the target density was achieved.



10.

In the sections of concrete around the CT and MRI facilities on the first floor of the clinical building, stainless steel reinforcement was used to manage the magnetic shielding and interference issues.

Construction of concrete shielding

With such a large volume of shielding required, significant sections of concrete needed to be poured. Large pours create considerable shrinkage forces in the concrete, and with crack widths limited to a maximum of 0.2mm due to shielding limits, this drove the design pour sequence and reinforcement design, which was carried out to CIRIA C660 (early-age thermal crack control in concrete). Pour restraint conditions and construction sequencing required careful consideration and close

collaboration with the contractors to manage thermal cracking and ensure the safe construction of the vital concrete shielding.

One of the primary drivers in the pour sequence was to minimise the number of panels that were ‘locked in’ on either side by adjacent completed sections of concrete, as the ‘infill’ panels had stress levels and reinforcement requirements more than double that of panels with at least one free edge. Typically, for a 2m-thick wall with single edge restraint, 25mm-diameter reinforcement bars were placed at 125mm centres each way on both faces. However, heavier reinforcement up to 32mm and 40mm in diameter was required in locked-in panels. All reinforcement had staggered laps and 32mm and 40mm bars were joined using couplers.

By working closely with the concrete sub-contractor and Interserve, a detailed review of the pour sequence was carried out. This had a direct impact on the final detailed design due to its effect on the restraint conditions of each pour. The review informed the agreed programme sequence, shutter design and the logistics for each concrete pour.

Arup provided a detailed specification for the thermal conditions, with minimum and maximum delivery temperatures for the concrete of between 15°C and 25°C. Thermocouples were placed in each pour to measure the differential temperatures between the core and the surface – this



8.



9: The cyclotron was lifted carefully into place using a large crane

10: A full-scale pre-construction concrete test pour was carried out, including conduits, pipework and thermocouples

9.

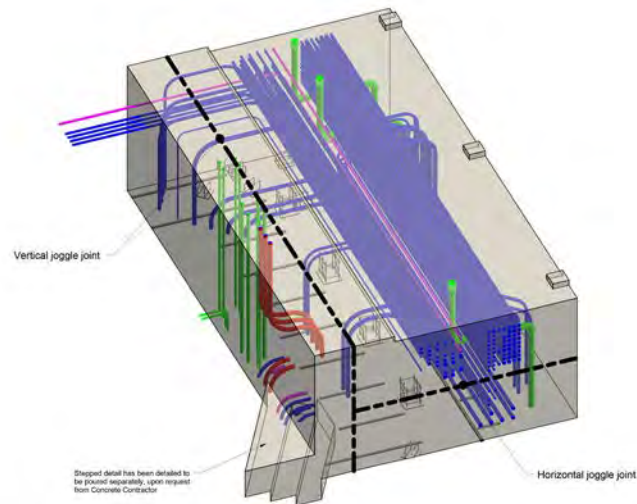

11: 3D view of concrete shielding, showing conduits, pipework, air ducting and thermocouples

12: The BIM model enabled early clash detection and construction sequencing

13: Along with the 11km of conduits, 1km of pipework was embedded in the shielding walls

14: The Christie has a BREEAM 'Excellent' rating

11.

needed to stay within a 30°C range. This fed into the decision of when formwork could be struck and removed. The largest single pour required 650m³ of concrete – equivalent to 105 concrete wagons – and 103 different pours were carried out overall. Some 17,000m³ of concrete was constructed over a 12-month period, using 1,700 tonnes of reinforcement with 538 embedded conduits and pipes and 140 embedded steel plates, all placed to exacting tolerances.

Federated BIM model

Arup, HKS Architects and Varian Medical Systems produced an integrated BIM model that included the PTE services requirements. By incorporating programme information within the 3D digital model, this 4D BIM model helped create projected

savings, measured at around £1.95 million, through early clash detection and site sequencing.

The model enabled the coordination of approximately 11km of conduits and piped services through the 3–5m-thick radiation shielding walls. All the individual embedded elements, including each reinforcement bar, were modelled and coordinated in 3D using Revit. This enabled the production of a set of drawings that detailed the plans, sections and elevations for each element in the pour, noting the specific setting-out requirements. The model also helped the contractor to design in safe access and temporary works during construction, as workers needed to be able to install conduits from inside the reinforcement cages.



14.

The BIM model was also used by the radiation protection adviser, Aurora Health Physics, to undertake a detailed Monte Carlo simulation that confirmed the final shielding requirements for the scheme. The simulation modelled the radiation emitted from the PTE and predicted the radiation profile within the defined geometry of the shielding vault and entry mazes. It included suitable allowances for the embedded ducts as well as the key concrete

15: The centre treats adults and children, and many elements have been designed with children in mind

16: The Christie opened in December 2018 and has treated many patients who have some of the most complex forms of cancer



15.

material properties, including the critical density requirements.

Future flexibility and development

The Christie PBT Centre has been designed for future adjustability, with the loading and performance criteria in the structural solution aimed at balancing capital costs with flexibility. The fourth gantry room, initially installed with a fixed beam outlet only, is currently used for research by the University of Manchester. This area was designed to receive a full rotational gantry, meaning the room can be re-fitted as a treatment room. Arup's design allows the equipment to be lifted through the roof by a crane supported

on the vault roof, which was constructed using removable pre-cast concrete planks.

Specialist centres

The Christie PBT Centre welcomed its first patient in December 2018, and it has since treated many patients with cancers that are complex to treat due to their proximity to vital organs. A second PBT centre is currently being constructed at University College Hospital London, set to open in 2021. Arup was responsible for the building services design for the concept design through to the planning application stage, and is now acting as technical adviser for the construction stage.

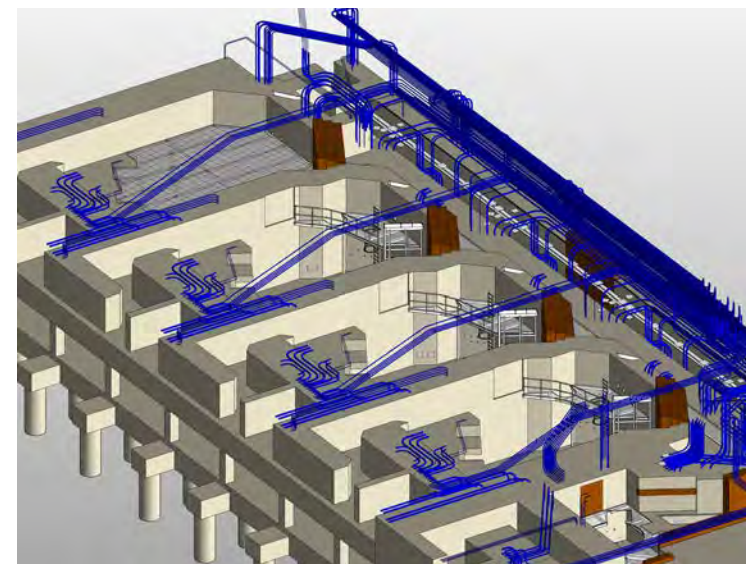

12.

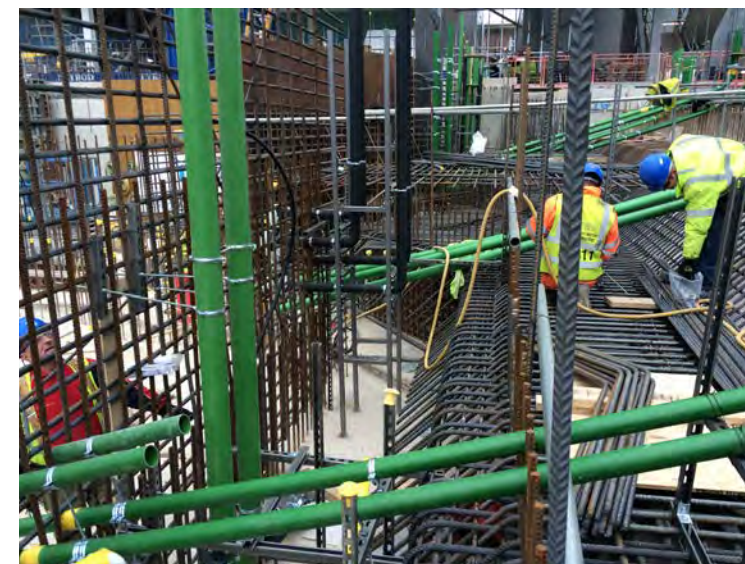

13.



16.

Authors

Nick Ashby was the director for the civil and structural aspects of the project. He is an Associate Director in the Cardiff office.

Hywyn Jones was the lead building services engineer on the project. He is an Associate in the Cardiff office.

Dave Pitman was the Project Director. He is Arup's Healthcare Business Leader in the UK, Global Electrical Skills leader and is based in the Cardiff office.

Project credits

Client The Christie NHS Foundation Trust

Architect HKS Architects

Design and build contractor Interserve Construction Ltd

Radiological protection adviser Aurora Health Physics Ltd

Cost consultants Gleeds

Civil, geotechnical, public health, structural and vibration engineering, building services and acoustic consulting Arup:

- Iain Adcock, Likhitha Ala, Sam Al-Noah, Waleed Alsharifi, Nick Ashby, Chris Bailey, James Banks, Rhys Baynham, Ian Bell, Ryan Blakeley, Geraint Bowen, Adrian Bull, Jason Burke, Steven Burrows, Lee Carl, Olly Carlton, Natalie Chamberlain, Sarah Clarke, Ashlee Corbett, Mike Cronly, Lewis Cullinane, James Davies, Ian Drabble, Sam Drury, Jiao Du, Chris Evans, James Evans, Nicole Evans, Tom Flitcroft, Rae Gee-Wing, Martin Gormley, Susie Gregory, Georgia Hall, Jim Harbord, Rob Harrison, Steven Harvey, Justin Howell, Martin Howley, Caroline Jarvis, Andy Jefferson, Richard Jeffs, David Jones, Hywyn Jones, Kevin Jones, Sion Lewis, Cath Lloyd, Pat McDonough, Phoebe McNeil, Darrell Milman, Izabela Miniewska, Dan Morey, Sam Morgan, Con Murray, Meguel Nurse, Sean Owen, Oliver Pike, Dave Pitman, Robert Powell, Michal Prochaczek, Anthony Rabaiotti, Derek Roberts, Kel Ross, Iain Scott, Yin Shan Ho, Leigh Sharman, Victoria Shattock, Sam Shooter, Tom Slater, Steve Smith, Martin Stanley, Ryan Taylor, Jamie Temple, Sherine Tsang, Jason Tse, Laura Wardak, Emma Warren, Patrick Welch, Chris Wheeler, Gary White, Adam Williams.

Image credits

1, 2, 4, 5, 14–16: The Christie NHS Foundation Trust

3: Varian Medical Systems

6–13: Arup

A living room for a city

A vast industrial space has been transformed into a meeting and knowledge hub that serves the whole community

Authors Simone Collon, Rob Verhaegh, Babette Verheggen and Mathew Vola

The spoorzone (railroad zone) district of Tilburg in the Netherlands is a 75ha former industrial area that was previously the town's railway hub. Purchased by the city in the 1990s, the district is being renovated as part of plans to transform it into a thriving urban area, providing work and recreation facilities for the local community.

A critical feature of the spoorzone is a huge double-bay hangar situated by the main railway station. Built in 1932, and originally owned by Dutch Railways, the structure consists of two separate, similar-sized halls that served as a locomotive repair and build space, and a boiler repair shop. But in recent years it has lain empty. The municipality wanted this space to be transformed so that it could be used by the people of Tilburg and act as a 'living room for the city', where everybody, young and old, could gather together and use a range of facilities.

The refurbishment of this once industrial hall has transformed it into a welcoming, modern,

mixed-use building that is equipped for making and retrieving knowledge. LocHal has a variety of functions. The redevelopment has 11,200m² of floor area and contains a bleacher-style area that also acts as a site for events and talks; Kunstloc Brabant, a knowledge and expertise area for culture and art; an auditorium; Midden-Brabant Library; a coffee house; a 60m-long winter garden; offices; and several workshops and labs that have been designed for an array of activities (there is, for example, a Games Lab, a Food Lab and a Dialogue Lab).

Brought on board by CIVIC, the lead architect, Arup provided multidisciplinary services, including structural and building services engineering, building physics, fire safety, lighting and acoustic design consultancy.

Retaining the past

The enormous 15m-tall hangar, which had fallen into a state of disrepair over the years, has a 90m x 60m footprint. The architectural vision was to retain as much of the original



2.



1: Constructed in 1932, the original building was used to repair and build locomotives
2: LocHal now acts as a 'living room for the city', with a variety of areas where people can meet and partake in various activities

1.



3.

structure as possible. Arup carried out a detailed inspection and organised a geotechnical investigation; this enabled the firm to advise on which structural elements could remain in use, and which would need to be replaced or reinforced.

In the building's previous life, locomotives were driven into the hangar on train tracks, before being lifted off by giant cranes. The original portal steel frame structure and the concrete ground-bearing slab on grade had therefore been designed to withstand significant loads. In the few areas where new foundations were required, the slab was locally demolished to create space for new piles to be constructed. These were grout-injected drilled piles, and only 81 new piles needed to be installed.

The old crane construction was still present in the hall and found to be structurally sound; this was retained and used to suspend the new composite steel concrete floors of the upper levels. The existing building columns were also kept, where possible. These not only support the roof, but also the cranes that are found on two different levels. In the areas where additional support was required for the suspended floors, Arup designed a new support system between the columns using trusses at a height of 5.4m.

The locomotive tracks, embedded in the concrete floor, have been kept as a distinctive feature in the refurbished hall. They are now used to move three giant wheeled 'train' tables.

These can be brought together to form a bar, or even a stage, and can be moved outside. One of the lowered working pits – used to access the locomotives from below – has been transformed so that it can function as an office space or working area. It is covered by an orange furniture element that functions as a mezzanine and contains further workspaces, as well as providing external views.

LocHal has large floor-to-ceiling windows along its façades. To reduce waste, Arup replaced this only where absolutely necessary, so much of the building's glazing is part of the original structure. The original brickwork of the east façade has been kept.

The client wanted the refurbishment to breathe new life into this old building, but

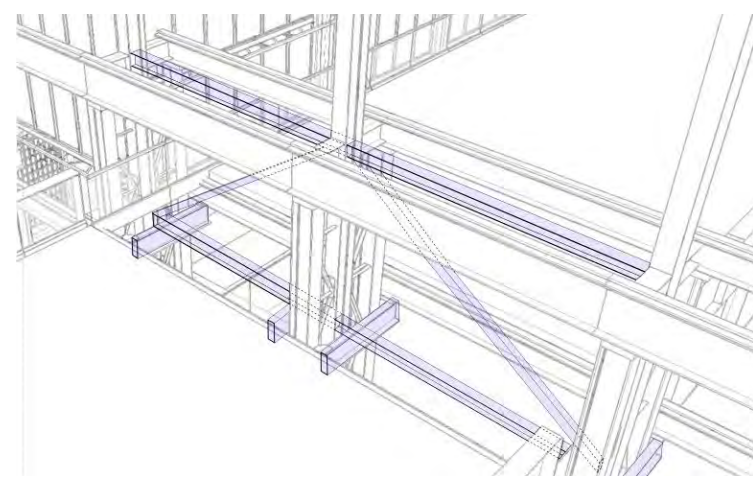

4.

Awards

World Architecture Festival 2019
World Building of the Year Award

BNA 2019 awards
(Dutch Association of Architects)
Liveability & Social Cohesion (winner)
Public Prize (winner)

without entirely eradicating its history. Rather than paint over LocHal's original columns, Braaksma & Roos, the heritage architect, chose to show the columns' patina after years of use and then neglect, with the peeling paint lending the hall an authentic, industrial air – in keeping with its past. These columns have been fitted with lighting and wooden tables, giving them a new lease of life as study areas.

Adaptability

As a 'living room for the city', it was important that LocHal had adaptability so that it could best meet the changing needs of users. In addition to the mobile train tables, the stairs area has moveable oak seating elements, so that people can create semi-private areas for either individual or group use.

Rather than rely on fixed internal walls that offer little flexibility, there are six full-height textile screens that can be moved to divide the space in different ways. These have a combined surface area of 4,125m² and are controlled electronically. The screens are a further nod to Tilburg's past, when it used to be known as a 'textile city', and the cloth curtains were made locally. As well as being functional, they provide a softening acoustic element in the industrial hall.

3: The giant textile screens can be used to divide the space in different ways

4: Where additional support was needed, Arup designed a new support system between the columns consisting of trusses of various sizes



5.

Climate

As a large, once industrial building, there were many challenges in providing a comfortable climate throughout LocHal. The client was also keen that the heating and cooling should be as energy efficient, and therefore sustainable, as possible. Arup conducted detailed on-site research and used advanced simulation models to create a successful solution. The firm adopted the ethos of 'heating people, not places', aiming for a clever use of space, with a minimal number of heating/cooling installations and an efficient use of energy. It developed three different strategies for the three kinds of space in the building: open space, semi-open space and enclosed spaces.

In winter in Tilburg, when outside temperatures can average about 4°C, the temperature in the open spaces inside the hangar can range between 10°C and 15°C.

Arup decided to opt for an intermediate climate in this area. Heaters were installed close to the doors and heating elements placed along the walls that contain substantial glazing. In order to provide a comfortable climate at all times of year, it was decided to use a displacement ventilation system. With such a system, 'fresh' air is pumped in from outside. This air warms up on contact with people and then rises, thereby creating a temperate climate and ensuring a continually circulating atmosphere. The system requires lower air speeds and less air than typical ventilation systems and therefore has a lower level of energy consumption. It was installed under the broad stairs leading up to the upper level of LocHal, and in panels in the walls in some parts of the upper level.

The steps, where people can sit, read and work, were designated as a semi-open space. Here, it was estimated that winter temperatures

5: Lighting and wooden tables have been added to the structure's original columns, which can now be used as study areas

6: Displacement ventilation systems were used for the intermediate climate areas of the building

7: Oak blocks in the bleacher-style seating area can be used to create semi-private areas

would average around 15°C to 18°C. Underfloor heating was installed in this area. This does not encourage long stays, but allows people to relax for a short time while they read or work or meet friends. This flexible, user-led heating is energy efficient and creates a comfortable experience for visitors.

The enclosed spaces, such as the laboratory areas that can be used as meeting rooms, the library offices or the gaming area underneath the stairs, all have their own temperature control.

While temperatures can plummet in winter, in summer they can rise to up to 33°C in the open spaces, with the structure difficult to cool in a sustainable and economically viable way, again due to its size. Pre-existing openings in the roof are utilised so that hot air can flow out and sun-resistant skylights were installed in order to limit the amount of direct sunlight entering the hall. To further minimise heat build-up, solar control double glazing was installed in the glass façade at the front of the building.

Arup's solution to controlling the atmosphere of the hangar meant that it was possible to retain it as one area; previously, the municipality had believed it would need to be divided into two halls due to the difficulties inherent in heating or cooling such a large space. Arup's climate solution has enabled LocHal to have a spacious feel that adapts to many different uses. It has also enabled sightlines within the building to be retained and encourages communal interactions.

Acoustics

The open character of LocHal meant that the acoustics in the space had to be carefully considered before installing the various

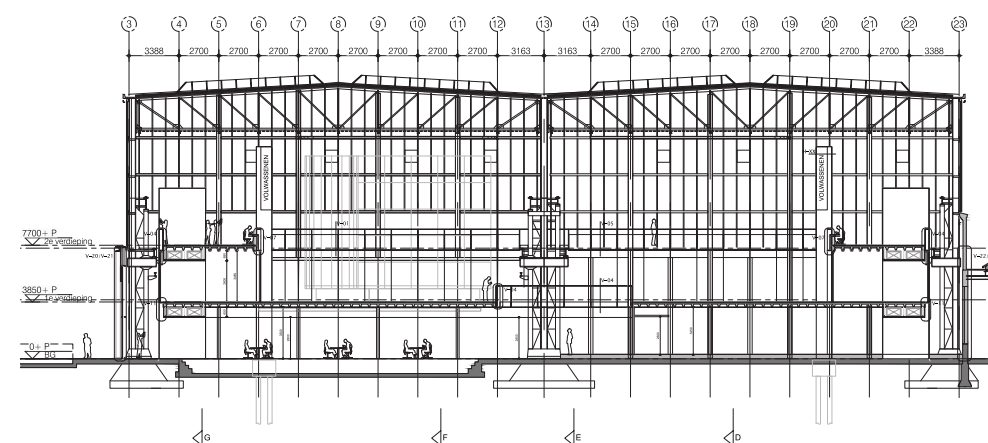

6.

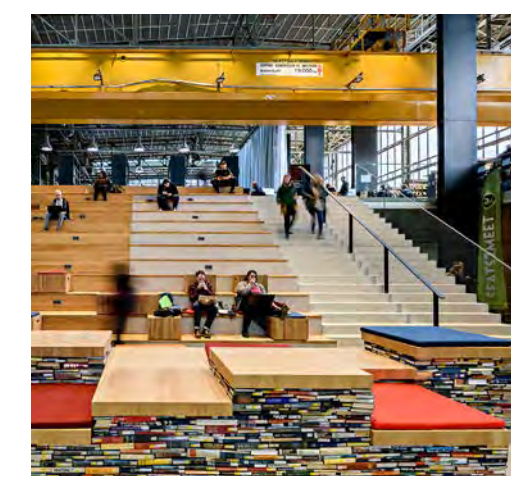

7.



8.

features. As a single mixed-use area, sound levels overlap, and noise travels far, especially as the space is constructed from materials such as steel and concrete, which amplify sound.

The coffee bar area is situated at the entrance to LocHal, creating a lot of noise. At the same time, the library areas need to be quieter, as do the areas where people can sit and study.

In order to attain client buy-in, and to inform the layout of the hall, Arup conducted in-depth auralisations. These demonstrated the sound levels in different parts of LocHal in various design iterations and were a way of demonstrating the complexities of the acoustics in an accessible way.

Lighting

Natural lighting is used as much as possible. The large glass façade and partly restored

mLab

To conduct auralisations, Arup used the mLab, a mobile version of the firm's SoundLab technology. mLab is a cubicle designed to be used in noisy settings, such as busy indoor conference centres. Once inside the lab, noise from the surrounding environment is shut out entirely. As with a recording studio, there are sound-absorbing materials on the interior panels.

Within mLab, bespoke software combines advanced virtual reality (VR) and 3D audio to experience the sounds produced in different built environments.

Until recently, designers of architectural space have had to rely heavily on their sensory memory of certain experiences or spaces to guide their design decisions. Qualities of light, sound and space can sometimes be described in words or numbers, but these metrics often fail to fully

rooflights allow daylight to flood into the building, creating an ambient atmosphere for users and retaining links with the outside.

The many different zones of LocHal, which each have a different function, meant that Arup's lighting team had the challenge of creating various lighting atmospheres. These had to ensure each zone had its own specific feel (which was also appropriate to its usage), while also retaining an overarching style throughout the building, ensuring that

communicate the experience. With the mLab, the sensory experience of architecture and environment can be simulated, thus going further than numbers and words. This approach allows the study of the subjective qualities of design and space, giving a deeper insight into how the spaces feel visually and sonically.

The simulations run by Arup's acoustics experts via mLab helped the client and design team to make choices at an early stage regarding the layout in the hall that would generate the most appropriate acoustics in all parts of the mixed-use area. For example, the library and study areas have been placed towards the back of the hall, far from the coffee bar area. The tiered seating area, which can be used for large gatherings and presentations, was tested in such scenarios to see what it would sound like when at full capacity.

each area, although distinct, felt like part of a coherent whole.

The tall ceiling of the main open hall meant that a lighting programme had to be developed in this area that would provide the right levels of light for people studying or meeting friends. Pendant luminaires were used; positioned quite close to the ceiling, they still supply light at a high enough intensity for people to comfortably converse and study. Pendant luminaires were also used

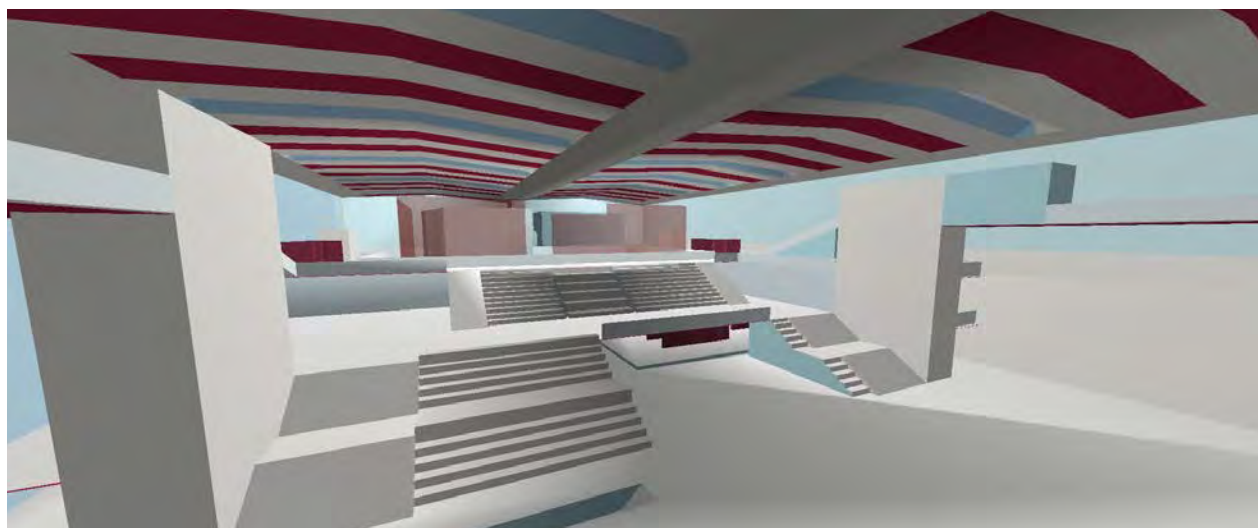

9.

8: Arup's mLab technology helps to give deeper insight into how spaces will sound
9: Arup carried out building modelling to help with the challenging acoustic design in such a large space

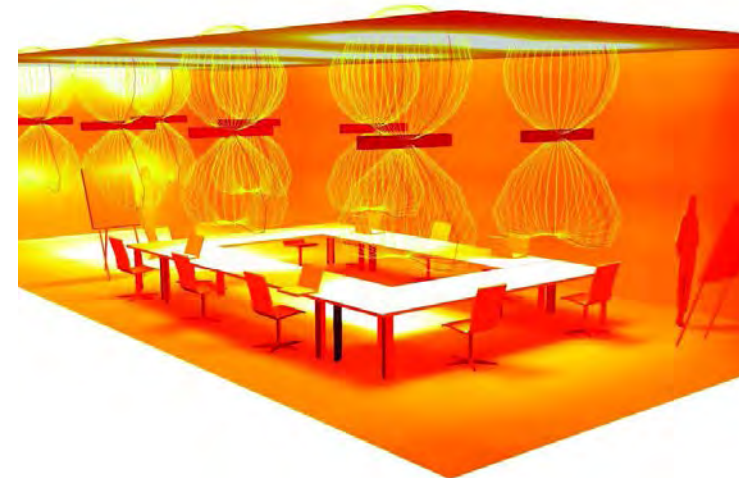

10.

in the open workspaces in order to retain a consistent architectural image.

Where possible, the lighting team retained the building's industrial heritage luminaires, retrofitting them with new technology. Lights were added to the building's columns in order to improve wayfinding and to enhance the details of the historical construction, further emphasising the building's character.

The lighting scheme is predicated around low energy usage principles.

Sustainability

At every point, elements of the original structure were retained rather than replaced, so as not to waste materials. Going a step further, LocHal has also helped to preserve materials from other

buildings. The historic glass room from the Beurs van Berlage (the old stock exchange building in Amsterdam, which is now a conference centre) was due to be demolished, but the City of Tilburg bought it for €1 and transported it to LocHal. It now has a new function as a glass auditorium and small concert hall venue within the LocHal complex.

A new community hub

Open every day from 8am to 10pm, LocHal is a vibrant hub in a once-quiet part of Tilburg. Offering spaces for people to meet, study, attend events and visit exhibitions, it is a welcoming knowledge centre and an inspiring example of how to breathe life into an old building. Situated at a connection point for several roads and adjacent to Tilburg train station, LocHal is now a new centrepiece for the community.

10: Analysis was also conducted for the different types of lighting needed for the various spaces

11: Arup's acoustic design means LocHal retains its spacious feel but can adapt to many different uses

12: Located in a vibrant, rejuvenated area, LocHal is now a centrepiece for the community



12.

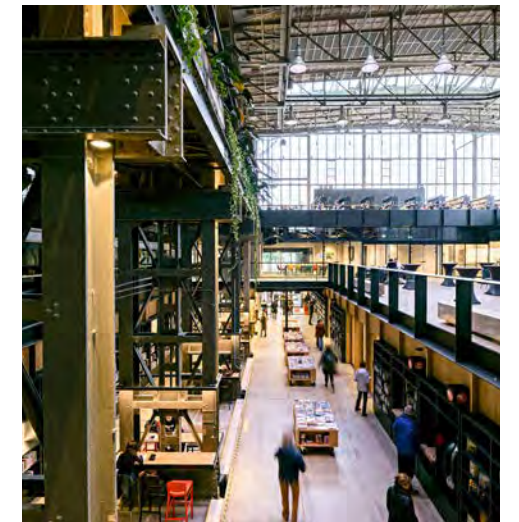

11.

Authors

Simone Collon is a lighting designer and an Associate based in the Amsterdam office.

Rob Verhaegh is a senior engineer, who was involved in the structural design for the project. He is based in the Amsterdam office.

Babette Verheggen led on building physics and acoustics and sustainability. She is an Associate in the Amsterdam office.

Mathew Vola was Project Director. He is a Director and Property Business Unit Leader in the Amsterdam office.

Project credits

Client City of Tilburg
Architect CIVIC, Braaksma & Roos, Inside Outside
Interior designer Mecanoo
Construction management Stevens Van Dijk Bouwmanagers & Adviseurs
Main contractor BINX Smartility
Acoustics, building physics, building services engineering, fire engineering, lighting design and structural engineering, Arup: Enny Breure, Simone Collon, Antonio D'Aquilio, Solmaz Esmailzadeh, Bettine Gommer, Michiel Hagenouw, Sander Hofman, Bart Kramer-Segers, Ander Perez Palacios, Camille Pfeiffer, Ouïam Rhersellah, Kevin Truijens, Rob Verhaegh, Babette Verheggen, Mathew Vola, Pieter Wackers, Hielke Wagter, Tom Warger.

Image credits

1: Regionaal Archief Tilburg
2, 3, 5, 7, 11, 12: Arjen Veldt Fotografie
4, 6, 8-10: Arup



From food to fuel

At O·PARK1, food waste is converted to energy and compost without creating a stink

Authors David Pegg and Michelle Shun

Hong Kong is a food lover's paradise. Its strong tradition of food culture embraces both regional delicacies and fusion foods that reflect its long history of international trade. But the moniker 'culinary capital of Asia' comes at a price, with over 3,000 tonnes of food waste produced every day in the territory.

With food waste the largest municipal solid waste category being sent to landfill, Hong Kong's Environmental Protection Department put in place a strategy to develop a number of organic resources recovery centres that would make effective use of this waste and help reduce carbon emissions. Phase one of the project, O·PARK1, which opened in July 2018, converts food waste into energy and compost.

The first organic resources recovery centre in Hong Kong, and one of the largest of its kind in Asia, O·PARK1 is located on a 2.2ha site on Lantau Island and has the capacity to treat 200 wet tonnes of source-separated organic waste each day. The food waste, generated by commercial, industrial and institutional establishments, is digested by micro-organisms, which then produce

1: O·PARK1, which opened in 2018, turns organic food waste into biogas, which is used to generate energy

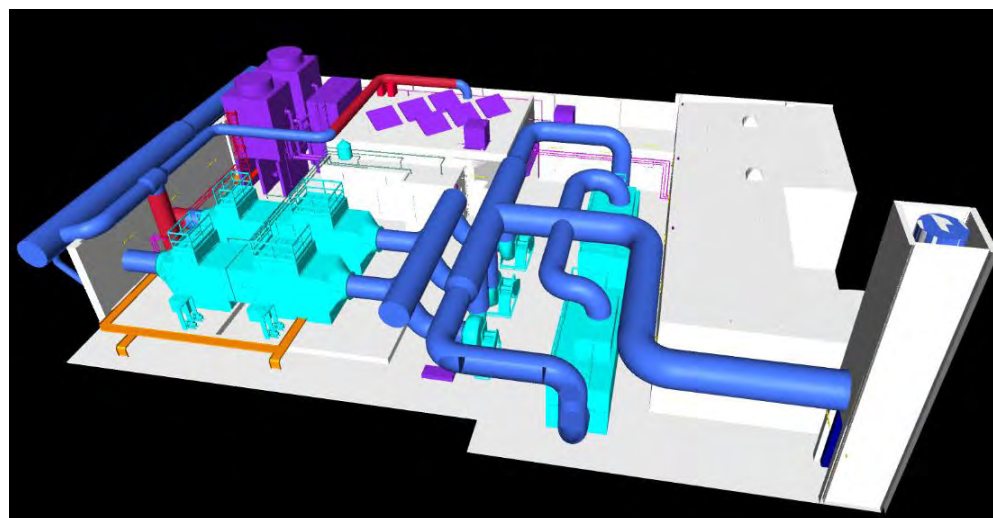

2.



3.

2: It was essential that Arup addressed the issue of bad odours created by the facility. A CAPCS treats the air before it is discharged

3: The composting hall has a flat soffit, which maximises headroom and minimises ventilation volume

4: The spaces created by the inverted beams on the roof have been filled with planters, helping to green the site

hour (ACH) in the main process area and wastewater treatment plant, plus 10 ACH in the pump room, it found that the air discharge volume would exceed the limit set forth under the environmental impact assessment.

Arup overcame this challenge by first, minimising the volume of every space, particularly the composting hall (one of the most odorous environments on site), where it used an inverted beam design to reduce the internal size. Second, the firm implemented a cascade air flow strategy to make efficient use of the air that was drawn into the facility buildings.

Inverted beam design

With the aim of maximising the operational headroom while minimising the ventilation volume in the composting hall, Arup proposed inverting the structure to use upstand beams, leaving the soffit of the hall flat, effectively moving the unusable void between beams onto the roof. In addition to decreasing the internal volume without impacting the operational headroom, the design created a clean ceiling surface. Arup assigned only the bare minimum of utilities here – lighting and sprinklers for fire services.

With the inverted beams creating compartments on the roof, Arup turned this arrangement into an advantage. The rectangular voids between beams have been filled with compost produced on site and used as planters to grow vegetation. This helps to green the industrial plant, which overall has 30% green coverage.

Cascade air flow strategy

The cascade air flow strategy proposed by Arup also helped reduce the total volume of air that needed to be treated and discharged



4.

biogas. This biogas powers the facility and is used to provide around 14 million kWh surplus electricity to the grid annually. Every element of the process has been carefully considered for its environmental impact, with the digestate converted to about 6,500 tonnes of compost per year and wastewater either reused or treated before being discharged to the public sewer.

O-PARK1 was procured by the local government under a design-build-operate contract with an 820-day design and construction phase and an operating period of 15 years. The contract was awarded to consortium OSCAR Bioenergy Joint Venture, comprising Suez, Atal and RosRoca, with Arup acting as the designer. Arup provided detailed design services, including architecture, structural engineering, geotechnical engineering, civil engineering, process (centralised air pollution control and

wastewater treatment), electrical, building services, fire strategies, landscape architecture and BIM.

Air discharge

As the first in a series of O-PARKs, a central plan of the O-PARK1 brief was proving to the citizens of Hong Kong that this type of facility would not tarnish their communities with bad odours and pollution. Arup responded with a strategy that ranged from rigorous facilities cleaning to a negative pressure site design that would draw air inwards in order to prevent odours escaping, and a centralised air pollution control system (CAPCS) to treat the air before discharge.

However, the government also set the air discharge limit for the site at a stringent 130,000m³ per hour. When Arup assessed the facilities' enclosed volumes to be treated and allowed for the required 12 air changes per



5.

by making efficient use of the air drawn into the facility. In total, the strategy cut down consumption, and therefore discharge of air, by two-thirds, simultaneously lowering energy consumption by reducing the amount of air being treated.

Arup analysed the operator's normal operations to find out which areas would be unstaffed and which would need operator access. The firm then configured the plant into zones such that fresh air would enter buildings in staffed areas, before being drawn into areas with restricted staff access and a medium pollutant load, and finally into unstaffed areas with high dust content before being treated by the CAPCS.

The CAPCS comprises two wet scrubbers that remove dust from air coming from the composting building, a chemical scrubber with a two-stage acid and alkaline cleaning process to remove ammonia and hydrogen sulphide, and an activated carbon filter, which discharges to the stack.

Green and clean

Odour control was considered in such great detail that every truck exiting the site is required to be washed. However, space constraints were such that there was no room for the trucks to manoeuvre from the weighbridge to the tipping bunker and washing facilities in a linear fashion.

To overcome the issue, Arup combined the tipping bay and the wash bay into one unit with two rapid-roll doors – one at the front, one at the back. In order to retain the odour seal, the back door is shut when vehicles enter, with the front door closing behind them before they are given

access to the bunker via the back door. When the tipping process is complete, the truck is once again sealed between the two doors, where it is washed.

Any water that runs off from the wash is collected, reprocessed and reused on site to



6.

5: Fresh air first enters the facility in the staff areas

6: In order to best use the limited space, the tipping bay and vehicle wash bay have been combined

7: O-PARK1 is able to treat 200 tonnes of biodegradable waste every day



7.

minimise water consumption. Wastewater that comes from the dewatering process of the food waste residue after anaerobic digestion (AD) is also treated and reused in the pre-treatment process (crushers and sieves).

O-PARK1 generates around 14 million kWh of electricity per year through the AD process, which produces a biogas rich in methane that can be used for both heat and electricity generation. The biogas is purified and dehumidified before feeding into the highly efficient combined heat and power (CHP) units for power generation. As well as being self-sufficient in terms of its own energy consumption, the plant powers up to 3,000 households annually as a result of the surplus electricity it feeds into the grid. The renewable energy that powers the site and local homes, combined with the carbon emission savings that would otherwise arise from landfill, reduce greenhouse gas emissions by 25,000 tonnes each year.



8.

8: The plant produces enough energy to power up to 3,000 houses per year
9: The open-air elevated walkway allows visitors to gain a good view of the site
10: 3D BIM was used to conduct swept path analysis on vehicle movements around the site

Look and feel

Ensuring the waste trucks look and smell clean is part of the wider initiative to ensure the facilities are amenable to the community while having a minimal negative effect on their neighbourhoods. O-PARK1 is situated adjacent to a major highway near the airport and is visible to the public. It was therefore important to adopt an aesthetic design that harmonises with its surroundings.

The brown-grey building cladding was selected to match the mountains behind, while the large airducts running from the compost building to the chemical scrubbers were placed along the link bridge so that the deodorising process is visible. On the roof, cladding was used to hide the pipework and the chemical scrubber, making the site seem less industrial. The architects allowed a slot on the front face that gives visitors a hint of the pipework

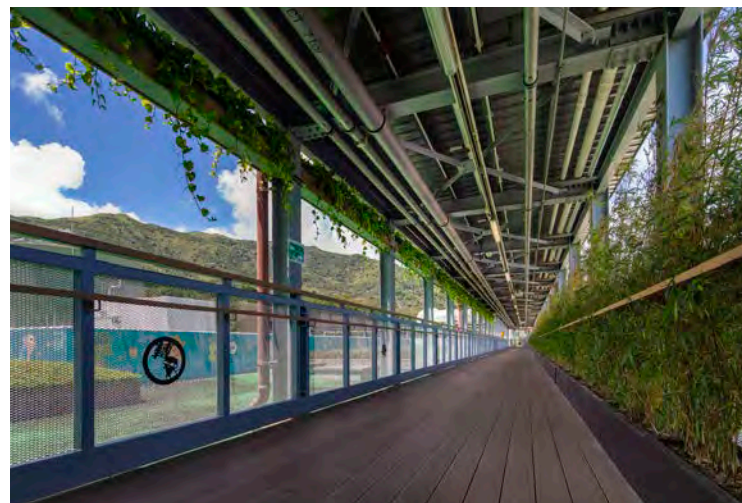

9.

and is used by the contractor to load and unload equipment.

The stack was designed to minimise its visual impact, with Arup proposing a rectangular rather than circular construction. By changing the height and width ratio in this way, the stack is less obvious. The rectangular shape also allows for easy maintenance access.

Staff amenities were also considered in the design, with a courtyard garden set into the top floor of the office building. This provides staff with an open space, and glass walls along the garden's perimeters give the office and conference rooms extra sunlight.

Visitor experience

An important strength of Arup's design was its thinking behind the visitor experience, which was vitally important for educating the general public. The firm's Architectural

team helped configure the plant in such a way that visitors could experience it without coming close to the operational areas. Visitors are able to walk through the site and view the core processes from a protected environment, with the inverted beam design acting as a talking point that highlights how much thought has gone into odour control. An open-air elevated walkway is central to the design, giving views across the plant but also allowing visitors to hear and observe the industrial environment. From the bridge they can see how the site blends into the natural setting, with mountains behind and the sea on the other side. They can also see the AD tanks where the crushed food waste is converted to biogas, and the wastewater treatment plant in the middle of the site.

After the link bridge, visitors come to a visitor gallery where they can look down through skylight windows into the composting area, providing views of the normal working processes, such as trucks taking the compost from one tunnel to another. The bunker area where organic waste is tipped and crushed is also visible. Visitors thus can see the site operations from a safe distance, allowing them to be educated about the way the plant works.

BIM

There was no formal requirement to use BIM but because Arup had designed similar facilities using the technology, it went ahead with this strategy. As the project developed, both Suez and Atal also adopted 3D BIM, meaning that the whole project has been completed in BIM. The model was also used to carry out a swept path analysis to simulate vehicle movements around the site to ensure these could be undertaken safely.

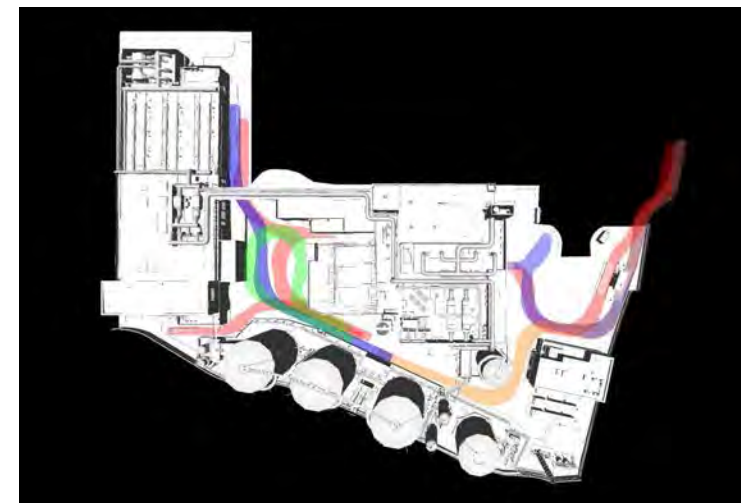

10.



11.



12.

Arup also developed a virtual reality application that integrates with the 3D BIM model, allowing the client to assess operational and maintenance tasks before entering the real environment. The client is able to use 3D goggles to 'walk' through the plant and visualise a particular job, such as removing equipment from a difficult space, which is helpful for safety and operational training as well as planning.

O-PARK2

Work began on the next stage of the government's plan, O-PARK2, in October 2019 and it is scheduled for commissioning in 2022. The plant, located in Sha Ling in the region's northern New Territories, will adopt advanced technologies to recycle 300 tonnes of food waste per day into biogas and other useful materials. Arup's role on the

project is to provide independent certification of the design deliverables and, through a team of site-based engineers, provide independent certification of construction and commissioning activities.

Arup is also helping the Hong Kong government to identify additional waste facilities up to 2041. This work includes a pilot trial of a food waste pre-treatment facility for co-digestion, combining sewage sludge and food waste in the same anaerobic digester tank to create biogas.

As the client explores the future of organic waste management, O-PARK1 stands as a testament to what can be achieved, reducing landfill volume by around 73,000 tonnes each year while producing renewable energy and compost.

11: Work on O-PARK2 is already under way. It is expected to be commissioned in 2022

12: The plant has over 30% green coverage and has reduced landfill volume by 73,000 tonnes per year

Authors

David Pegg was the Project Director. He is a Director in the Hong Kong office.

Michelle Shun was the Project Manager. She is an Associate in the Hong Kong office.

Project credits

Client Environmental Protection Department, Hong Kong Special Administrative Region
Contractor OSCAR Bioenergy JV
Architecture, building services, civil, fire, geotechnical, process and structural engineering and sustainable infrastructure design Arup:

- Ryan Adi-Putra, Karma Barfungpa, Mathew Brown, Christy Chan, Patrick Chan, Thomas Chan, Vince Chen, Joseph Cheng, Hilary Cheung, Ray Cheung, Hilda Chiu, Harry Choi, Yiu-Bond Choi, Elaine Chow, Carrie Chu, Mohammed Danish, Nilda Galvez, Aatisha Gupta, Don Ho, Rex Ibanez, Berlin Ip, Aniruddh Jain, Thomas Jiang, Yiu-Fai Kan, Jason Khoo, Cammy Kong, Dominic Kwok, Kathy Lai, King-Chak Lai, Romario Lai, Kwan-Yau Lam, Maggie Lam, Sharjeel Larik, Morize Lau, Yee-Ting Lau, Joey Law, Vincent Law, Bill Lee, Jason Lee, Kam-Tim Lee, Kitty Lee, Siu-Yuen Lee, Brian Lei, Andy Leung, Gavin Leung, Louis Liu, Franky Lo, Edie Luo, Carlson Ma, Martino Mak, Wilson Mak, Arnd Manzewski, Dhaval Mehta, Candy Mok, Giuseppe Mollica, Andrew Ng, Angel Ng, Calvin Ng, Kenneth Ng, Roy Ng, Raymond Pak, Simon Pearce, David Pegg, Edgar Po, Dora Shum, Kin-Pui Shum, Michelle Shun, Iota Sin, Taurino Singson, Andy So, Edith So, Edward Stonehill, Susanne Sugiarto, Raymond Sy Guan, Stanley Sze, Albany Tam, Grace Tam, Megan Tang, Paul Taylor, Morriz Tsang, Simon Tsang, Sum Tsang, Alex Tsoi, Ricky Tsui, Muhammad Umer, Raymond Vega, June Wang, Billy Wong, Calvin Wong, Ensen Wong, Eugene Wong, Louis Wu, May Yam, Daphne Yan, Alan Yang, Sam Yau, Sunny Yip, David Yu, Doris Zhang.

Image credits

- 1-7, 9, 10:** Arup
- 8, 12:** Heliservices (HK) Ltd
- 11:** Google Earth DigitalGlobe

A new vision for air travel

SFO's new terminal leads the way in sustainable travel that considers users' wellbeing

Authors Raj Daswani, Raphael Sperry and Byron Thurber



1.

1: SFO's new terminal is named after civil rights leader Harvey Milk

2: Arup was the multidisciplinary consultant on the Boarding Area B design-build team. It was also lead airside engineer



2.

Terminal 1 at San Francisco International Airport (SFO) was originally built in the 1960s. Increased demand for air travel over the decades since – and particularly since 2000 – meant that it could no longer handle the passenger volumes that were passing through every day; an upgrade was needed, but the client wanted this to be carried out without affecting flight schedules or passenger experience.

The 1.2 million ft² (110,000m²) Harvey Milk Terminal 1 project involves major modifications and rework to the Terminal 1 Center, the complete demolition and rebuild of Boarding Area B, and upgrading Boarding Area C. Ageing infrastructure has been replaced, aircraft taxilanes realigned, and temporary and permanent facilities constructed.

Arup served as the largest multidisciplinary consultant on the design-build team for Boarding Area B that was selected by SFO in late 2015. The firm worked on aviation planning and analysis, civil engineering, sustainability consulting, fire engineering, building services, and acoustics/audio-visual services. Arup was also appointed lead airside civil engineer, which entailed the design and construction administration of the 30-acre apron and taxilane reconfiguration.

Construction began in 2016, with the first nine new gates of Terminal 1 opened in July 2019. Stage 2, a further nine gates, opened in May this year, with nine more gates set to be up and running by mid-2021. When complete, it is planned that Terminal 1 will operate approximately 400 flights per day.

In 2018, the City and County of San Francisco bestowed the terminal with the name Harvey Milk in honour of the US Navy veteran, County Supervisor and civil rights leader (1930–78), who was the first openly gay elected official in California's history.

Creating sustainable flight

SFO has long been concerned with sustainability, with its Strategic Plan 2017–21 setting out the airport's aim to become – among other goals – entirely net-zero energy by 2021. As part of the plan, SFO wants to achieve zero waste, reduce its greenhouse gas emissions by 50% (from a 1991 baseline), maximise water conservation, and implement a healthy buildings strategy for new and existing infrastructure. SFO set up a Zero Energy and Resilient Outcomes (ZERO) Committee, which was charged with reviewing all airport projects (both those under way and those in planning and design stages), including Boarding Area B. The review was to confirm compliance with the

airport's strategic sustainability goals for energy and water efficiency, carbon reduction, zero waste, and selection of systems, materials, products and furniture for improved planetary and human health.

Arup was responsible for the schematic energy design for Boarding Area B. The firm worked closely with the ZERO Committee, looking at ways to drive the energy usage of the terminal down even further, carrying out lifecycle costing, triple bottom line assessments across social, environmental and economic considerations, and analysis of different mechanical systems.

The energy analysis process had two tracks. The first used building energy analysis modelling software IES, which was run by Engineering 350 under Arup's supervision, to assess the building energy load (including areas such as heating, cooling, ventilation and lighting). The second track analysed airport-specific loads that could not be so easily measured by IES. These included the high-mast lighting that illuminates the airport apron and taxiways; the elevators and escalators throughout the terminal; the equipment-charging stations (for baggage tugs and aircraft pushback tractors), which are charged via the terminal; the baggage handling system (BHS), and the aircraft themselves, which when parked can plug into the terminal's electricity and can also access ventilation from the end of the passenger boarding bridges.

Having metered various equipment in the past, SFO had data that Arup was able to use to determine which aspects of the airport used most energy, and where savings could be made. Two critical areas were highlighted following a review of this data – the heating and cooling systems, and the BHS.

Modular baggage handling

Terminal 1 previously operated with six disparate baggage systems, each owned by different aircraft carriers. The systems were complicated to coordinate and also used a significant amount of energy. They needed to be streamlined – replacing the different systems with a shared one – and updated so that the new BHS could easily fulfil the needs of a busy, modern airport.

Most airports, including SFO, have a conventional belt conveyor BHS. Belt conveyors are driven by variable frequency drives and have one motor that powers a belt 20m to 30m long. If there is even one bag anywhere on this surface area that means the motor will be running, using power. In an individual container system (ICS), however, each bag is put into a separate container (also referred to as trays), each of which is 2m long.

The trays are conveyed on individually controlled roller modules rather than conveyor belts. If there is no tray on a module, no power runs to it. An ICS therefore uses half the energy of a traditional belt-type conveyor BHS. It also has greater capacity, managing up to 3,000 bags per hour on a single line, and has quicker transport speeds, meaning it is particularly useful in large airports where bags may have long distances to travel. The Boarding Area B pier is quarter of a mile long.

In a conveyor system, all the bags are sent to one storage room, which requires staff to be in attendance and sort the bags whenever needed. This introduces the potential for human error – if a mistake is made about a bag's destination, there is no double checking. In the modular system, bags are also sent to a storage room but with the difference that each tray has a radio frequency identification



6.



7.

(RFID) tag embedded within it. Once a bag is loaded into a tray, the bag ID is 'married' to the tray ID, with the containers tracked via their RFID tags. This means that sorting and releasing of bags can take place automatically, and if a bag fails a security screening, it can automatically be sent back through the system. By automating these complex actions, the chances of luggage being sent to the wrong plane are reduced, as are the staffing levels needed. Moving bags via trays also reduces the probability of bag straps or wheels catching on parts of a conveyor system and causing jams.

The design of the BHS was led by the Terminal 1 Center design-build team of Hensel Phelps, with the new system serving both Boarding Area B and Terminal 1 Center.

Arup collaborated closely with the designers and installers, Beumer. This is the first time such a system has been used in a US airport and Beumer provided an Environmental Product Declaration for the BHS – a first for the industry.

Heating/cooling systems

The other main area that Arup identified for energy savings was the heating/cooling system. As Boarding Area B is open 24/7, it uses a significant amount of electricity.

Arup opted to use a displacement ventilation system. This supplies air at a low velocity through large column covers and wall panels. It requires less energy, particularly when cooling a space, as the cooler air meets

people and then rises, meaning that the entire room does not need to be cooled. In a typical overhead cooling system, a lot more energy is needed, as air has to be pumped through the whole space, rather than just the lower couple of metres. Displacement air also travels at lower velocity, requiring less fan power.

The design also included radiant ceilings for heating and cooling in the hold rooms. This system is energy-efficient because rather than relying on air being pumped – which takes a lot of energy through the use of fans – the heating and cooling method uses water that is circulated through pipes. As well as requiring far less energy, this allows the air system to be smaller than it would otherwise be, thereby creating further cost savings and taking up less space.



3.



4.

3: Construction began in 2016, and was carried out in stages

4: The Harvey Milk Terminal is open 24/7, and therefore has significant energy needs

5: Arup's energy usage analysis included monitoring the use of the electric ground support equipment charging stations



5.

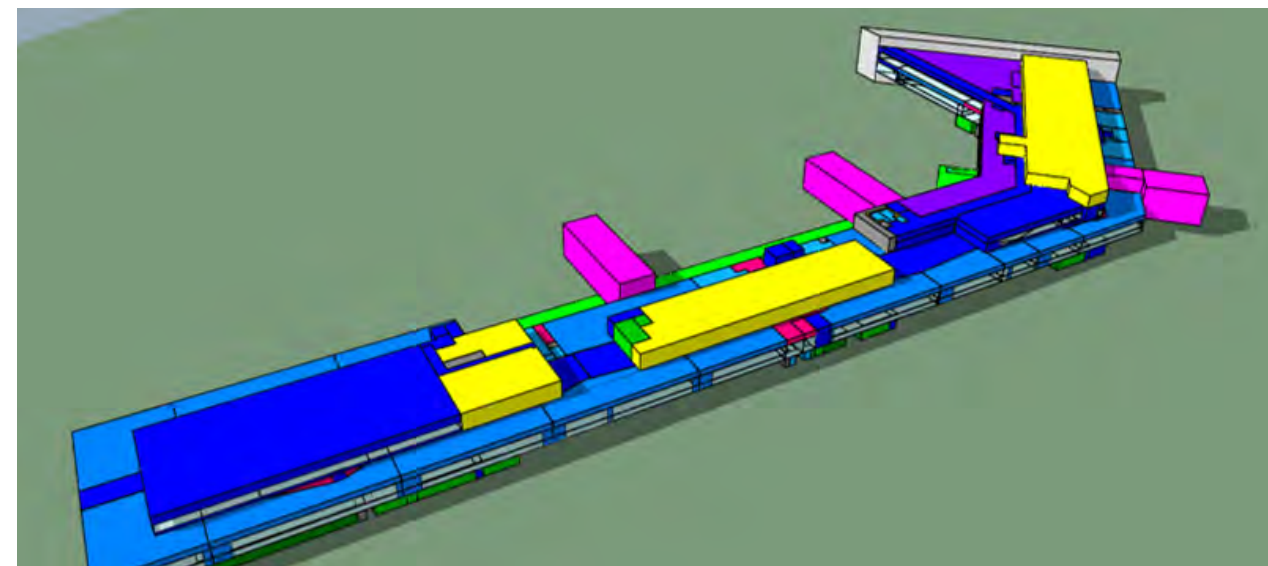

8.

6: When parked, aircraft plug into the terminal's power and air systems, improving outdoor air quality

7: The advanced modular BHS uses significantly less energy than a conventional belt conveyor BHS

8: Building energy analysis modelling software was used to assess the building energy load

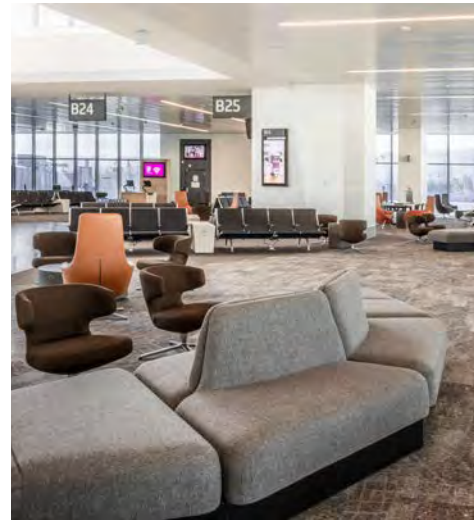
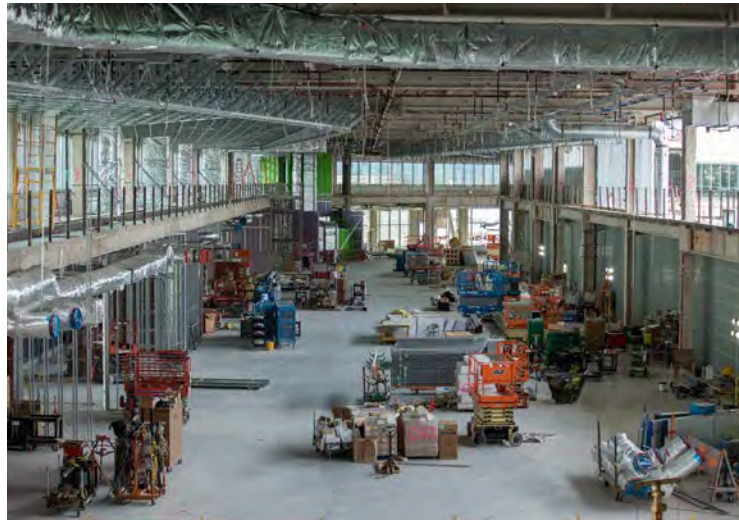

9.

10.

12.

13.

The radiant ceilings, combined with the displacement ventilation system, allow a wider band of air temperature to be supplied, ensuring passengers have a comfortable experience in the terminal.

Acoustics

Another consideration when installing the radiant ceilings was the acoustics of the terminal. Getting the right balance between the ceiling panels having the optimal thermal and acoustic performance was a complex job. Often, acoustics are better when an acoustic-absorbing back is installed behind the metal ceiling panel, with perforations made in the metal so that the sound can go through and be absorbed. This ensures that the many noises created in a busy terminal do not become too loud for passengers. However, too many perforations mean that there will not be enough metal to create a radiant effect to heat

or cool a space. Arup, along with the architect, HKS-Woods Bagot-ED2-KYA Joint Venture, worked to develop a perforation panel that could fulfil the terminal's thermal and acoustic needs.

Electrochromic glazing

As typical of many airports, SFO has large floor-to-ceiling windows. Such large areas of glass can mean uncomfortable glare in the morning and evening when the sun is directly in view. Arup helped develop a strategy that ensured window space did not have to be curtailed but could also prevent glare without the maintenance concerns or loss of view from window shades. After extensive consideration of various options, SFO opted for the installation of electrochromic glazing (or dynamic glazing), using View Dynamic Glass. This uses electrochromic technology to switch between clear and tinted states on

demand. It solves the glare problem, provides some energy savings on hot days, and ensures that unobstructed views and natural daylighting are retained.

Achieving sustainability

SFO's ZERO Committee asked Arup to analyse the design features of Boarding Area B to quantify their social, environmental and economic performance. With Autocase, a specialist consultant that conducts triple bottom line cost-benefit analysis, Arup estimated the costs of key features of the terminal renovation. The results showed the environmental and social benefits that would come from making certain choices during construction. For example, the radiant heating/cooling system delivered better air quality, which benefits the wider community through a healthier atmosphere and fewer cases of respiratory problems such as asthma.

The interior materials were all closely monitored and tracked, with Arup reviewing them against strict indoor air emission criteria. The global warming potential per square metre of carpeting was closely analysed; the carpet tile was selected according to the San Francisco Environment Code and to strike a balance between durability (due to high footfall) and environmental impact.

Reformulated wall board of a slightly lower density was used. This option included a lot of recycled content, thereby fulfilling circular economy principles and having a smaller carbon footprint. The spray-on insulation under the arrivals level floor slab is created from a bio-based material. All interior materials and furnishings are free of toxic flame retardants.

Arup carried out analysis of all the materials used in Terminal 1's construction for their contribution to the following environmental impacts: eutrophication (the impact of high levels of macronutrients); acidification (emissions that cause acidifying effects to the ocean); smog depletion (emissions that contribute to ground-level smog formation); and ozone depletion. Concrete, which has a high environmental footprint, primarily due to its cement content, was one of the main construction materials. The firm optimised the cement content of the structural concrete, replacing it where possible with alternative, less damaging, materials. By doing this, the embodied carbon footprint of the entire building was reduced by over 10%.

Passenger boarding bridges (commonly known by the trademark name 'Jetway'), which are composed primarily of steel, are

12: Arup analysed all the materials used in the construction of Terminal 1 to assess their environmental impact

13: Arup obtained an environmental product declaration for the passenger boarding bridges – a first for the building industry

one of the major equipment systems of an airport terminal. In a first for the building industry, Arup obtained a Health Product Declaration and an Environmental Product Declaration (the latter quantifies a product's environmental impact through its lifecycle) for the passenger boarding bridges, in order to better understand and improve their impact.

Harvey Milk Terminal 1 is targeted for LEED v4 BD+C Gold level certification, but once construction is complete, it might even be possible to achieve Platinum level.

Electric GSE vehicles

As part of its strategic plan to reduce carbon emissions, SFO has been incentivising airlines and third-party ground service providers to transition their aircraft ground service equipment (GSE) vehicle fleets from traditional diesel to electric, known as

'eGSE'. In a pioneering study that has now been replicated with several other clients, Arup's Aviation Analysis team performed a comprehensive requirements analysis to assess the optimal number of eGSE recharging stations per gate. A benchmarking study of comparable airports yielded a wide range of charging stations per gate and per eGSE vehicle, showing there was no evident consensus yet in the industry (as at early 2016).

Arup's analysis, which assumed an ultimate transition to a 100% electric fleet, took into account factors such as vehicle operating times, recharging times, sharing rules, numbers of idle or out-of-service vehicles, distance/convenience for staff, and battery life optimisation. This resulted in an evidence-based recommendation of four stations per small gate and ten stations per large gate.



11.

9: Arup installed radiant ceilings, which use water circulating through pipes for heating and cooling

10: Solar photovoltaic panels are used to generate electricity on site

11: The electrochromic glazing can be adjusted to prevent bright glare without the need to reduce window size or install blinds

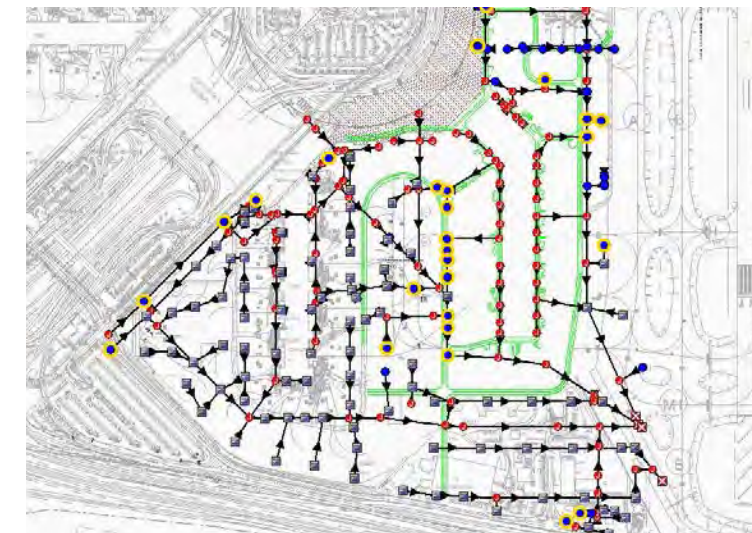

14.

14: Arup used its WeatherShift software to forecast future weather patterns and ensure the drainage system was resilient

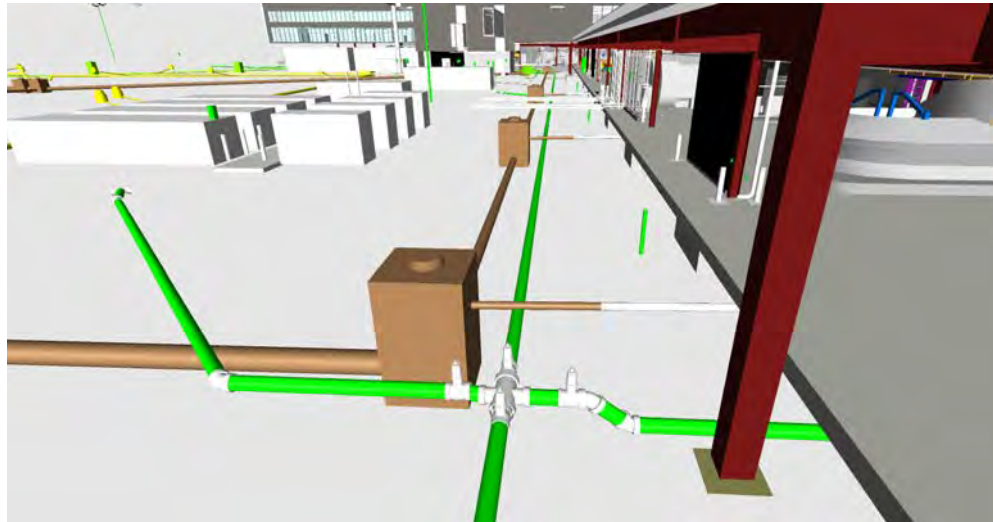

15.

In addition to generating electricity on site via solar photovoltaic panels placed on the roof, SFO purchases renewable electricity from the grid, so meeting the airport's longer-term carbon reduction goals.

WeatherShift

A vital part of creating a sustainable building is ensuring it is ready to meet future climate scenarios. To have a better idea of the kind of weather patterns facing SFO in the coming decades, Arup used its bespoke WeatherShift programme, developed in-house with Integrated Environmental Solutions and Argos Analytics. The tool uses climate change predictions for a local area to generate annual weather profiles to simulate future building performance.

Typically, design takes into account rainfall intensity-duration-frequency (IDF) curves, which are calculated based on the past 100 years of measured rainfall data. However, due to the rapid pace of climate change, calculating future weather based on the past 100 years is no longer considered reliable. WeatherShift uses data projections from several global climate models to construct weather scenarios that consider future weather behaviour.

Current weather profiles are 'shifted' to the future, meaning that buildings, infrastructure and urban masterplans can be tested to see how they withstand future weather patterns. By being able to plan ahead more accurately, lifecycle costs can be minimised, as resilience is built in, meaning replacement is not so frequent. WeatherShift can plot future temperature rises as well as rainfall IDF curves, both of which affect the choices made in the construction of the built environment.

Arup used WeatherShift primarily to assess the effects of future rainfall on the storm water drainage system for the airport apron. The tests showed that most of SFO's drainage was capable of handling the projected increase in rainfall intensity, but it highlighted a weak link in the system. In several areas, the drainage system of basins and pipes came together in nodes. WeatherShift's IDF curves showed that a small number of those nodes could become backed up due to the higher intensity of future rainfall. Arup was therefore able to mitigate this problem by upsizing the

- 15: WeatherShift showed the effects of predicted future rainfall on the airport's stormwater drainage
- 16: The airport parking plan has been upgraded to accommodate a modern fleet mix
- 17: The first nine new gates of Harvey Milk Terminal 1 opened in July 2019, and nine more opened in May 2020

affected nodes. By using WeatherShift, the firm could pinpoint with a great degree of accuracy this potential problem area and build in a solution – pre-empting the issue and saving on future costs.

Phasing and collaboration

This project was planned in stages in order to have minimal impact on airport users and flight schedules. A temporary set of gates was constructed before the old gates were demolished. This required detailed coordination among the teams on the project – the upgrade was split into two separate projects, Terminal 1 Center and Boarding Area B – who all worked together on site in a repurposed space within an unused hangar known as 'The Big Room'. This integration was highly successful, allowing for easy communication and



16.

coordination between the 120-strong group of design and construction professionals, airport personnel, and the project management support services teams. This created greater efficiencies at every step, in a collaborative delivery process novel for an aviation project.

The airside grading and utilities were modelled using AutoCAD Civil 3D – integrated into the project's BIM model using Autodesk BIM 360 Glue – to facilitate sharing, coordination and clash detection in a real-time 3D environment. This accessible platform provided a single shared space for the design and construction teams to design, collaborate, innovate, and ultimately construct and document the project.

Upgrading the airside

Arup's airside planning team, with industry-leading expertise in aircraft gate and apron design, developed a new aircraft parking plan that flexibly accommodates a modern aircraft fleet mix. This includes six gates configured as two-for-one multi-aircraft ramp systems, sized for A380 and future B777-9X aircraft types. In a first for SFO, vehicle service roads (VSRs) are provided at the head of stand, in addition to the traditional tail of stand. Head-of-stand VSRs facilitate a reduction in the number of potentially conflicting aircraft/GSE rolling interactions, and shorten the distances and travel times for GSE, resulting in improved safety and efficiency of aircraft servicing.

The aircraft stand configurations that Arup developed for Boarding Area B are now regarded as the new benchmark standard for future designs at SFO, and during the project the airside team has assisted with gate planning on adjacent projects at Boarding Areas A and C.

Enhancing the flight experience

The first nine new gates of Harvey Milk Terminal 1 opened in July 2019. Nine further gates opened in May 2020, with the final nine gates set to be completed in mid-2021. The redevelopment of Terminal 1 will enable it to handle up to 17 million annual passengers – a capacity increase of 70%, and a 70% decrease in energy use compared with the previous terminal. Passengers can enjoy a terminal catered to their comfort at every step, and can appreciate the many amenities on offer, such as high-end shops, food halls and an art gallery. And with its environmental impact closely monitored and mitigated wherever possible, the Harvey Milk Terminal also contributes to the wellbeing of wider society.



17.

Authors

Raj Daswani was Project Director for the duration of the project, and performed oversight of all building engineering services. He is a Principal in the San Francisco office.

Raphael Sperry was the Project Manager during the construction phase, and led on the sustainability and energy modelling aspects of the project. He is an Associate in the San Francisco office.

Byron Thurber was Lead Aviation Planner for the duration of the project, supervising the aviation planning and analysis work-streams. He is an Associate in the San Francisco office.

Project credits

Client San Francisco International Airport

Architect HKS-Woods Bagot-ED2-KYA

Joint Venture

Structural engineer Rutherford & Chekene

Main contractor Austin-Webcor Joint Venture

Civil, electrical, mechanical, public health and fire engineering, acoustic consulting,

audio-visual and multimedia, sustainability consulting, and aviation planning and analysis

Arup: Shakeel Ahmed, Jennica Autery, Josh Bird, Holly Brink, Jenna Browning, Alton Cannon, Camilo Chalela, Eglantin Dashi, Raj Daswani, John Dell, Haley Francis, Audrey Fremier, Ekaterina Frolov, Maribel Gibson, Cooper Glosenger, Geoffrey Griffiths, Justin Guan, Erica Hoffman, Peter Holst, Yeying Huang, Venon Jalali, Jun Lautan, Anh Le, Jackie Lee, George Long, Vineet Maheshwari, Alisdair McGregor, Grant McInnes, Kyle McMillen, Aarshabh Misra, Jack Mong, Elena Morosanu, Luis Nieto, Ramson Paulus, Rubina Ramponi, Todd Ravenscroft, Léonard Roussel, Raphael Sperry, Vojin Stefanovic, Jolene Stoffle, Nathan Stroud, Mark Summers, Aihua Tang, Larry Tedford, Sara Tepfer, Byron Thurber, Aldrin Tordecilla, Lauren Wingo, Frances Yang.

Image credits

1, 4, 9, 12, 13, 17: Austin-Webcor
2, 3, 5-8, 10, 14-16: Arup
11: San Francisco International Airport

Reconnecting communities

The rejuvenation of this riverside area has created green, open spaces for the public while also providing vital flood protection

Authors Carol Andrews, Chris Caves and Reuben Lucas



1.

Combining vital flood alleviation with a greenway project that connects communities, the Connswater Community Greenway is helping to transform East Belfast. The scheme is a 9km greenway that offers access to riverside environments, 16km of continuous cycle and walkways, improved and connected green and open spaces, new bridges, a public square, and heritage trails.

The linear park along the Connswater, Knock and Loop rivers provides a continuous, uninterrupted car-free corridor, allowing residents and visitors to walk, run or cycle from the Castlereagh Hills to the Titanic Quarter in Belfast Lough.

The needs of the local community drove the design, resulting in urgently needed flood alleviation measures combined with new green and public spaces. The works increased river capacity and attenuation, providing crucial flood protection for 1,700 homes and businesses and 40,000 residents. East Belfast was previously noted in travel guidebooks as a part of the city inadvisable for tourists to visit, but the greenway has helped turn that around. It has stimulated the local economy, drawn tourists to the area and is an attraction that the community can enjoy and be proud of. The interventions that were carried out support economic development, improvements in public health and community cohesion – allowing previously segregated communities to come together. Where rivers once acted as barriers, people and places are now reconnected, and healthier lifestyles have

- 1: The 9km Connswater Community Greenway provides flood alleviation measures, green spaces and access to the river
- 2: The linear park provides an uninterrupted car-free corridor from Belfast's Castlereagh Hills to its Titanic Quarter

been encouraged by a series of urban amenities throughout the greenway.

Arup played a central role in creating the Connswater Community Greenway by leading the project team during the design and construction stages of the extensive second phase of the development. As well as using the firm's civil engineering expertise, Arup deployed a wide range of additional technical skills, including geomorphology, transport, environmental design, community liaison, project management and site supervision services.

The development represents a £41 million investment (£30 million for the greenway and £11 million for flood alleviation), delivered by Belfast City Council in close collaboration with local social partnership organisation EastSide Partnership; Northern Ireland's Rivers Agency was an important collaborator on the project.

Community engagement
The genesis of the Connswater Community Greenway scheme began in 2005 as an application to the UK National Lottery's Living Landmarks scheme, designed to



2.

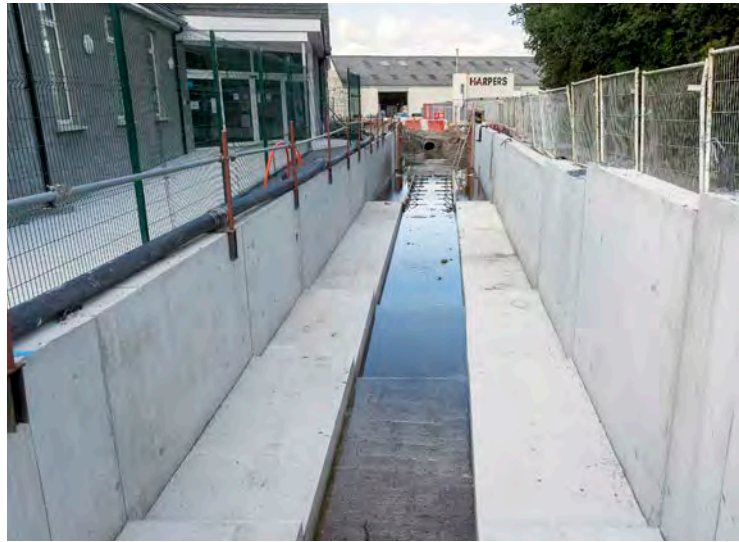

3: As part of the project's flood alleviation measures, 4.1km of reinforced concrete flood walls were installed
4: Arup engineered a series of pedestrian and cycle bridges as part of the greenway

3.

connect communities via open space. It then developed into a more ambitious greenway project with the goal of creating pedestrian-cycle routes and improving the public realm. The area surrounding the greenway is home to communities facing a range of socioeconomic and public health challenges, including low life expectancy, high levels of child poverty and subdued economic activity. EastSide Partnership wanted to overcome years of neglect and lack of investment in the area – poor-quality infrastructure was recognised as a particular barrier. An understanding of the needs of the local community was developed through a series of community engagement initiatives. Improvements in public health, societal cohesion and security from flooding were identified as critical priorities.

Sustained commitment to community engagement during the design and construction phase resulted in 550 meetings with homeowners and businesses, and nine larger community forums.

The project team went beyond the intermittent consultation required to fulfil statutory obligations, instead engaging with the local community continually. Responding to over 750 public queries across the four-year construction period, the team issued 12,500 notifications and updates to 6,640 Facebook and 4,584 Twitter followers, ensuring the community was aware of all the long-term benefits for the area, including the provision of improved flood protection measures for their homes. The process helped overcome scepticism in some sections of the community about the

development. For example, some residents who lived close to planned public entrances to the greenway were concerned about anti-social behaviour, and struggled to envisage the benefit of having new amenities on their doorsteps.

One of the project's significant technical challenges was access to the waterway, which in places was along a heavily confined urban corridor. Working closely with the local council, Arup managed the individual landowner agreements regarding purchasing land where required, agreeing timeframes, reinstatement and compensation for the works. This was a substantial amount of work given the linear scale of the project, the urban environment and the large numbers of landowners involved.

One of the most visible elements of the greenway is a series of new pedestrian and cycle bridges engineered by Arup. The scheme included 26 new or refurbished bridges, with seven new steel bridges and two small-span wooden ones. These serve as connections between communities, linking a network of green spaces. Where once the Connswater, Knock and Loop rivers acted as barriers to public movement, the area now facilitates sustainable travel and healthier lifestyles, and connects previously separated neighbourhoods while providing access to the riverside environment. Encouraging a sense of community ownership and stewardship was a priority, and a public nomination process was used to name a dozen bridges and five paths along the greenway. Local children created designs for the construction hoardings and amateur gardeners attended

contractor planting days. During construction, paid employment for 1,014 weeks was provided, split between the long-term unemployed, apprenticeships, graduates, training candidates and university students.

A phased approach to the greenway development meant that sections were opened and made accessible to the community as quickly as possible. This enabled the public to use the facilities and to quickly see what the overall project was aiming to achieve. Each time one of the sections was completed there was an open day, which helped to keep the momentum and goodwill towards the project going. The engagement has not stopped with the greenway's completion, as EastSide Partnership organises events on an ongoing basis including nature walks, charity runs and outdoor fitness classes. The greenway has also been included in the local geography GSCE and A-Level education curriculum.

Flood alleviation
A period of regular flooding in East Belfast provided a greater impetus for the project –



4.

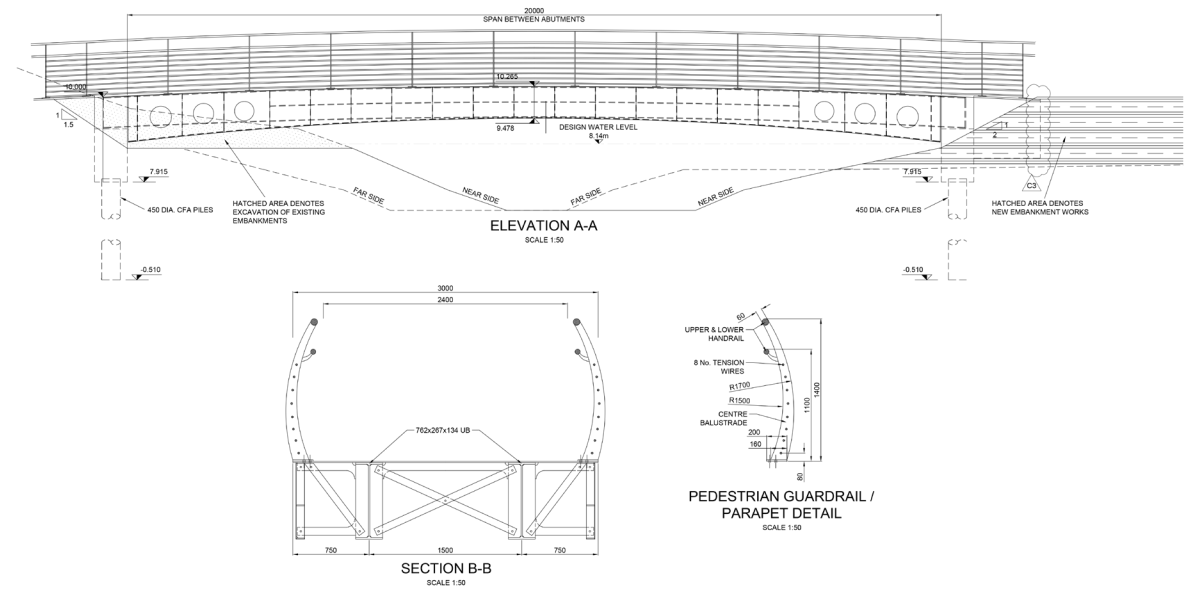

5.

the area was subject to flooding in 2007, 2008, 2012 and 2014. The three rivers that weave through this urban environment were prone to both fluvial and pluvial flooding, in addition to influence by tidal events. Belfast City Council and EastSide Partnership worked collaboratively with the Rivers Agency to incorporate the Connswater Greenway Corridor and the East Belfast flood alleviation scheme into one combined project. This approach maximised the benefits by combining procurement. It allowed Arup to produce enhanced integrated design solutions to augment the quality of the infrastructure delivered, minimise disruption to the community during construction and reduce the overall cost of the combined works.

With flood protection a priority, the project was split into two phases. The initial works in Victoria and Orangefield parks were done as part of the first phase, with Arup awarded the design work and supervision for the seven sections in phase two.

The flood alleviation measures along the greenway route included 4.1km of new reinforced concrete flood walls and 1.2km of flood embankments. Local and long-lasting materials were used in the design, with natural materials included where possible, particularly for the river restoration. Robust construction and detailing were essential, given the urban environment, 24/7 access and intensity of use. The major flood protection works were carried out towards

the Belfast Lough end of the greenway where the river level is influenced by the tide. Further upstream, the flood walls were replaced with banks, with a 5km river restoration scheme used at the far end.

River restoration
In the past, the path of the Connswater, Knock and Loop rivers had been artificially influenced. An important project goal was to restore the rivers to their more natural forms, thereby helping to increase biodiversity, encourage the riverside area's wildlife and ecology, improve their general appearance, and allow greater public access. Arup's geomorphology specialists

(based in Newcastle) made several recommendations that were implemented, including softening the river banks by removing debris and refuse – over 50 tonnes of rubbish was cleared from the waterway – and managing invasive species such as Japanese knotweed. Much of the Connswater River was previously confined to a blockstone channel, while other river sections were oversized and sluggish. All these elements encouraged a healthy, dynamic water flow, giving the river system a 'kick start', improving channel aesthetics and creating more diverse habitats through the fluvial and tidal sections.

5: Seven new steel bridges were constructed as part of the scheme's 26 new or refurbished bridges

Awards

2019
NCE 100 Award
Impact in Urban Living

2018
Institution of Civil Engineers
World's 200 most influential projects

Royal Institution of Chartered Surveyors
Northern Ireland awards
Community Benefit – Highly commended
Green Flag Award

British Construction Industry Awards
Community Engagement Initiative of the Year

2017
Northern Ireland Electrical Awards
Lighting Project of the Year

Sustainable Ireland Environmental Waste Management and Energy magazine
Environmental Initiative of the Year – Joint Winner

Construction Employers Federation (CEF) Excellence Awards
Social/Community Construction Award
Transport & Utilities Infrastructure Award

CEF Environmental Sustainability Award



6.

At the low water levels, natural brushwood bundles were tied together and fixed to shallow (75mm-thick) gabion mattresses. These were pinned to the existing revetments and filled with stone and brushed soil that allowed the planting and grasses to grow. The brushwood bundles encourage wildlife to nest more readily, especially compared with the concrete channels previously used in this area. Adapting stone revetments so that they take a more natural form, and adding native aquatic planting to them, has improved the rivers' ecological status as required by the EU Water Framework Directive. More than 1,400 native trees have been planted along the greenway.



7.



8.

Reflecting the best of Belfast

A new public square, CS Lewis Square – which is Belfast's first 24/7 park – sits at the heart of the scheme and was designed in what was an unused grass area at Hollywood Arches. Named in honour of the Belfast author, who was born in the area, the square is 2,500m² and features seven sculptures based on characters from Lewis's book, *The Lion, the Witch and the Wardrobe*. Along with its adjacent visitor centre, the square attracts more than 1,000 visitors each day and has contributed hugely to the regeneration of East Belfast through inward investment, employment and tourism. Sustrans, a charity that makes it easier for people to walk and cycle, has an Active Travel Hub adjacent to the square

6: Playparks and multi-use games areas have been established along the greenway

7: Natural brushwood bundles were attached to gabion mattresses and filled with stone and soil so that plants and grass could grow

8: The Conn O'Neill Bridge – which dates from 1603 – was strengthened as part of the project

providing bicycle hire, repairs and cycling workshops. The Belfast Bikes ride-sharing scheme was extended out from the city centre to the square and there is also a stop for the hop-on hop-off tourist bus.

Recreation facilities in the form of playparks and MUGA (multi-use games area) pitches were installed, with connections to the adjacent local schools to allow easy access for children to the play areas. Eight tourist trails have been established to celebrate the history and culture of East Belfast, including an industrial heritage tour. The Van Morrison Trail is named after the singer, whose most famous song, 'Brown Eyed Girl', references the hollow that is located on the greenway. The Conn O'Neill Bridge in the same location, which dates from 1603, was strengthened as part of the greenway project. The George Best Trail tells the story of the former Northern Ireland and Manchester United footballer who grew up in East Belfast and was a Glentoran FC fan, attending games in the Oval football stadium located adjacent to the final section of the linear park.

Greenway success

Queen's University Belfast was commissioned to measure the effects of the new infrastructure on the surrounding area and quantify the impact. The Physical activity and the rejuvenation of Connswater (PARC) study measured the mental and physical health effects Connswater has had on the community. One of the study's key conclusions is that if only 2% of the inactive

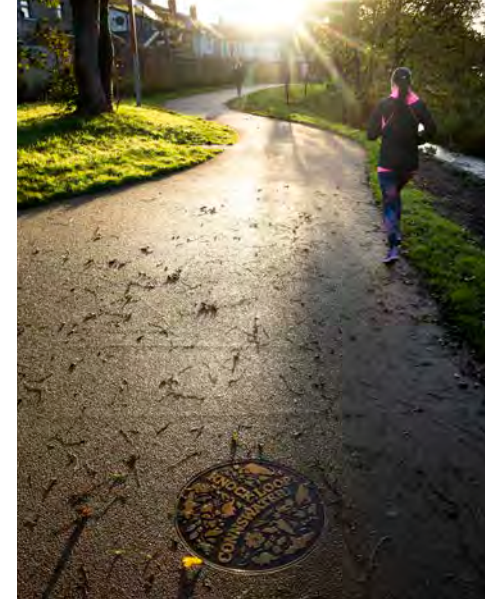

9.

population in East Belfast become active because of the greenway, the scheme will pay for itself through health benefits in 40 years. This equates to a potential economic return of £500 million – more than 12 times the project cost.

A core goal of the greenway is to encourage healthier and more active people and communities and to improve the public health of locals. This includes 40,000 residents, the pupils and students attending the 23 schools and colleges along the route, and those who work and invest in the



10.

community. The number of people using the greenway area for play and recreation has doubled to 556 per hour when surveyed six months after opening. And thanks to the greenway's well-lit paths and outdoor fitness facilities, another important social outcome is that the community is safer. The PARC study noted a reduction in the perception of litter and vandalism in the area, as well as a perceived reduction of crime.

Another goal of the project was to contribute to the economic regeneration of East Belfast through investment, employment and tourism. Parts of East Belfast that were previously unwelcoming are now busy with dog walkers, joggers, pedestrians and cycle commuters. CS Lewis Square draws tourists into this part of the city, with the square and greenway tourist destinations in their own right. The river restoration, coupled with the flood alleviation works, has encouraged the community to return to the river when for years they had turned their back on the waterway. There has been an increase in planning permissions for developments along the greenway, including refurbishment of existing houses (focusing the homes towards the river), along with apartments, shops and businesses popping up along the route. More than 1.4 million pedestrians, cyclists and anglers are using the greenway each year. This project demonstrates the power of green infrastructure and how it can contribute to a city's wider community and economic development goals.

9: The greenway has brought together several communities in East Belfast and created a vibrant area enjoyed by locals and tourists

10: CS Lewis Square contains sculptures of characters from the author's most famous book

Authors

Carol Andrews was responsible for supervisor duties on the project. She is an Associate in the Belfast office.

Chris Caves was the Project Director. He is the Infrastructure Leader for Arup in Northern Ireland and a Director in the Belfast office.

Reuben Lucas was the Project Manager/Lead Designer and is an Associate in the Belfast office.

Project credits

Client Belfast City Council/ EastSide Partnership

Landscape architects Paul Hogarth Company

Cost managers ChandlerKBS

Contractor Farrans Construction

Bridge engineering, civil engineering, flood risk management, programme and project management, and sustainability consulting Arup:

Carol Andrews, Imelda Barry, Chris Bolt, Laura Brady, James Calvert, Will Campbell, Ken Carter, Simon Cattley, Chris Caves, Andrew Clarke, Stacy Clements, Mark Coalter, Candice Constantine, Francesca Crossan, Jack Davies, Matthew Dowie, Ciaran Elliott, Meghan Fick, David Hetherington, Nevin Keane, Jagadeesh Kunnumal, Gareth Lawlor, Nigel Livingstone, Cian Long, Reuben Lucas, Donncha Madden, Suzanne McColgan, Emma McFarland, John McGill, Christopher McGuinness, Megan Moore, Keith Morrison, Rachel Murnaghan, Chris Norman, Pawel Ogonowski, Tara O'Neill, Aled Phillips, Tomasz Pietruniewicz, Andrew Richardson, Dave Ross, Corrado Ruta, Eamon Scullion, Holly Shearer, Darren Stewart, Peter Storey, Annelie Syk, Marian Thompson, Killian Walsh, Tammy Whelan, Dominik Zolnowski.

Image credits

1, 3, 4, 6, 9, 10: Paul Lindsay/ Christopher Hill Photographic

2: EastSide Partnership

5, 7: Arup

8: Paul Megahey

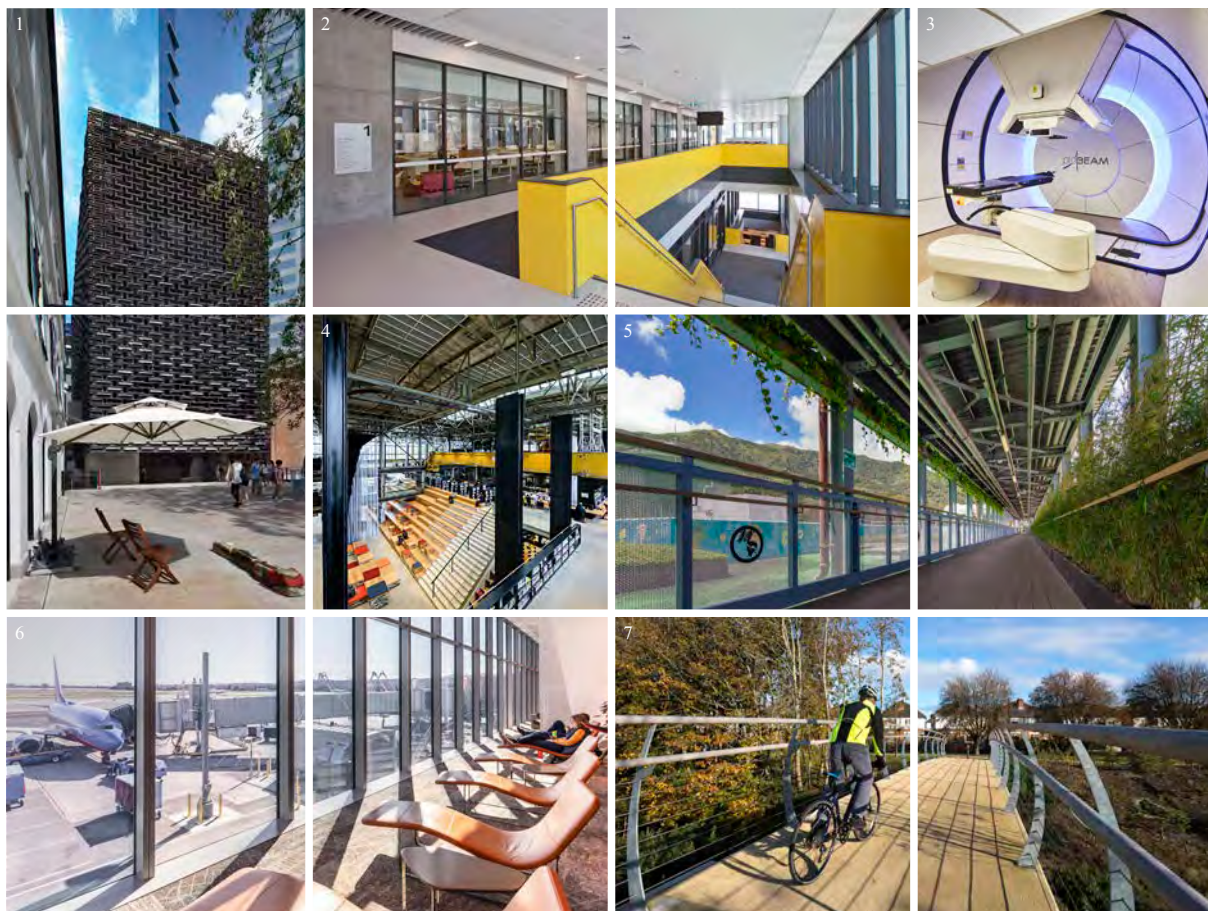

1. Tai Kwun, Hong Kong: *Arup*; 2. UNSW Science and Engineering Building, Sydney, Australia: *Multiplex*; 3. The Christie Proton Beam Therapy Centre, Manchester, UK: *Christie NHS*; 4. LochHal, Tilburg, Netherlands: *Arjen Veldt Fotografie*; 5. O-PARK1, Hong Kong: *Arup*; 6. Harvey Milk Terminal 1 at San Francisco Airport, San Francisco, USA: *Austin Webcor Joint Venture*; 7. Connswater Community Greenway, Belfast, UK: *Paul Lindsay/Christopher Hill Photographic*.

Front cover image: Tai Kwun, Hong Kong: *Arup*.

The Arup Journal
 Vol.55 No.2 (2/2020)
 Editor: Maccara Ferris
 Designer: Wardour
 Email: arup.journal@arup.com

Published by Arup
 13 Fitzroy Street
 London W1T 4BQ, UK.
 Tel: +44 (0)20 7636 1531
 All articles ©Arup 2020

Printed by Geoff Neal Group
 Produced on FSC® paper
 and printed with vegetable-
 based inks.

